

Glass level gauge

Model LGG

KSR data sheet LM 33.01

Applications

- Continuous level indication without supply voltage
- Direct indication of the level
- Individual design and corrosion-resistant materials make the products suitable for a broad range of applications
- Chemical industry, petrochemical industry, oil and natural gas extraction (on- and offshore), shipbuilding, machine building, power generating equipment, power plants
- Oil and gas, heat transfer and refrigeration systems, plants for cryogenics

Special features

- Process- and procedure-specific production
- Operating limits:
 - Operating temperature: $-196 \dots +374 \text{ °C}$ ¹⁾
 - Operating pressure: Vacuum to 250 bar ¹⁾
- Wide variety of different process connections and materials
- Illumination optional
- Heating and/or insulation optional

1) Individual limit values. For application limits, the joint consideration of temperature and pressure is required!

Description

The main element of the glass level gauge is the gauge body. Incorporated into this gauge body are the liquid channel (if necessary the heating channel) and the seating faces for the chambered seals and sight glasses.

Onto the gauge body are mounted, or are already integrated, the valve heads and process connections. Drain or vent are also possible.



Compact version with side pieces, model LGG-E

The glasses and/or mica shields as well as the seals are fitted, secured and sealed with the aid of U-bolts and covers or pressure frames. Glasses from borosilicate glass in accordance with DIN 7081 are used.

For steam, the glasses can be used up to 243 °C, with mica design to 300 °C. For other media, temperatures up to 300 °C are possible, in special cases up to 374 °C. The use of mica is needed for specific applications.

Operating principle

Reflex glasses per DIN 7081

In the viewing direction, incident light strikes the reflective grooves of the sight glass plate and is refracted into the liquid present. With gases, the light is reflected. Thus the level is visible as a dark column, the gaseous area as a silvery column over it.

Reflex glasses are very well suited for the display of clear liquids.

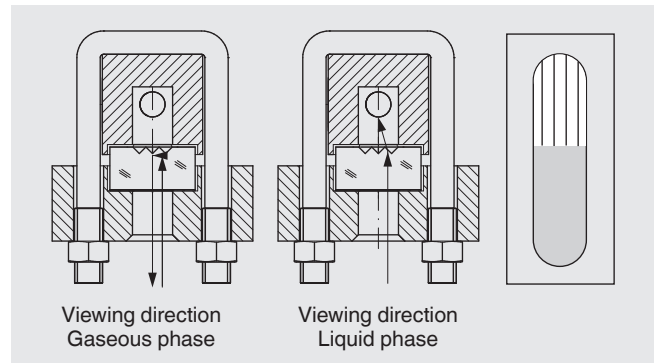

Transparent glasses per DIN 7081

From the rear, incident light passes through both sight glass plates with the media between them. The level is visible as a line (meniscus) or directly due to the liquid itself.

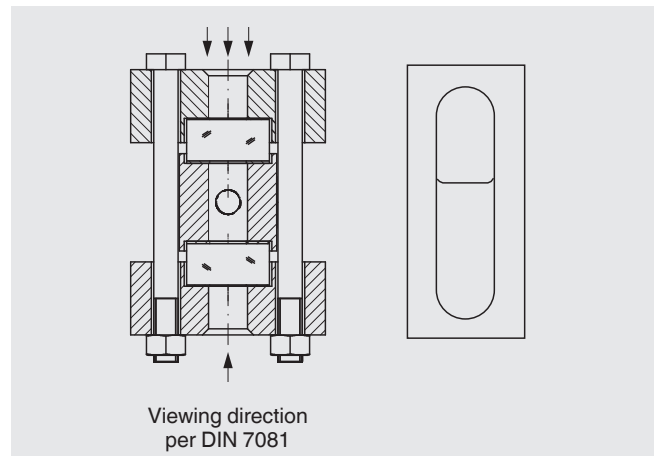

Refraction principle with mica shields

From the rear, incident light from a lamp passes through both mica shields with the medium between them. The lamp and medium are arranged at an angle. In the gaseous phase, the light passes directly through, with liquid, the light is refracted sideways. Thus the level is visible as a black column, the gaseous area as a light column over it.

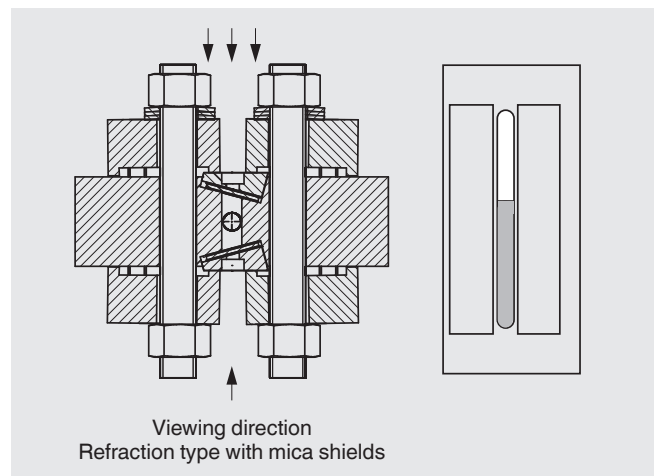

If unprotected sight glasses are used in boiler systems with aqueous media, high temperatures and high pH values can lead to increased glass erosion. The effect of glass corrosion is increased with the introduction of chemical additives, such as in water treatment. The geometric changes to the sight glass resulting from the erosion lead to risks in the operational safety.

For temperatures from 243 °C, KSR KUEBLER recommends the use of **transparent glasses with mica design**. These prevent chemical attack at high water temperatures on the otherwise unprotected glass.

Construction of glass level gauges

Gauge body

Base body of the glass level gauge, contains the liquid channel

Cover

For the clamping of the sight glass plates

Flat gasket

Chambered sealing between the liquid channel and the environment

Glass

Sight glass plates per DIN 7081 from borosilicate glass

Cushion

Mechanical protection between cover and glass

U-bolt, nut

Hold the forces from the internal pressure

Glass size

Standard lengths L of sight glass plates per DIN 7081, width 34 mm, thickness 17 mm

Visible length SL

The entire visible length in the sight glass, glass separations are included

Individual visible length ESL

Visible range of a single segment

Segment

Field of view consisting of a single sight glass plate

Glass separation A

Non-visible range, results from the linking together of segments

Example

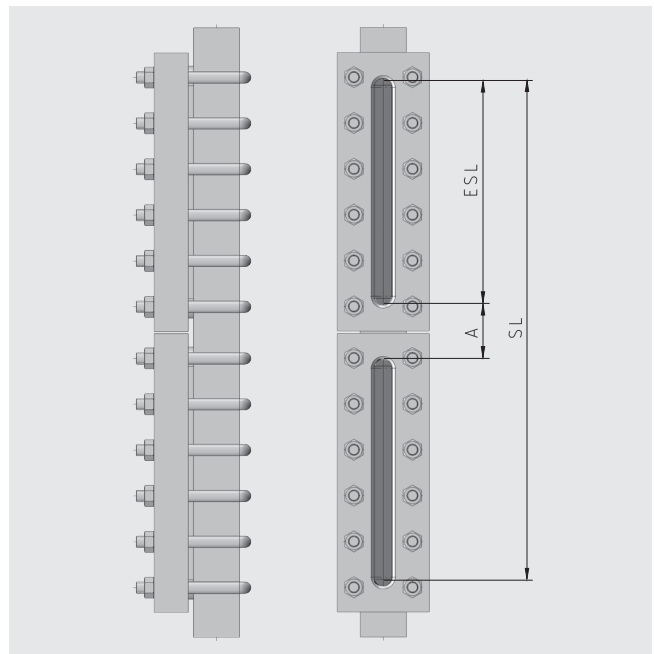
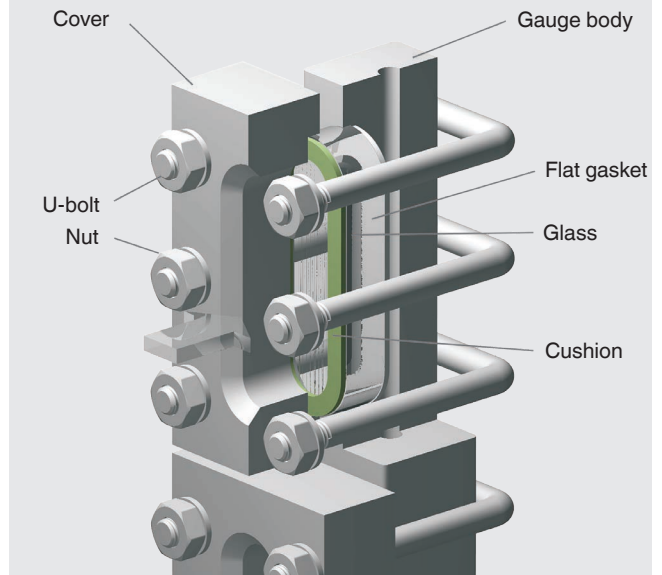

Visible lengths and glass sizes in mm

Length	Glass size									
	2	3	4	5	6	7	8	9	10	11
L	140	165	190	220	250	280	320	340	370	400
ESL	120	145	170	200	230	260	300	320	350	380

Number of segments	Visible length SL									
1	120	145	170	200	230	260	300	320	350	380
2	285	335	385	445	505	565	645	685	745	805
3	450	525	600	690	780	870	990	1,050	1,140	1,230
4	615	715	815	935	1,055	1,175	1,335	1,415	1,535	1,655
5	780	905	1,030	1,180	1,330	1,480	1,680	1,780	1,930	2,080
6	945	1,095	1,245	1,425	1,605	1,785	2,025	2,145	2,325	2,505
7	1,110	1,285	1,460	1,670	1,880	2,090	2,370	2,510	2,720	2,930

Matrix valid for glass separation A = 45 mm

The visible length SL can deviate from the specified value by ± 3 mm due to construction.

Valve heads

Valve heads isolate the vessel from the glass level gauge. They consist of the valve body and the head piece. They are actuated by a valve with quick closing lever or handwheel. In general, they are fitted with a ball-check valve as a safety element.

Valve body

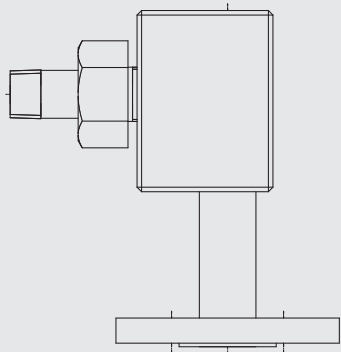

Head piece

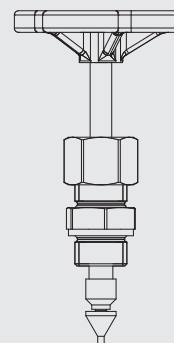

Valve with quick closing lever

Open anticlockwise

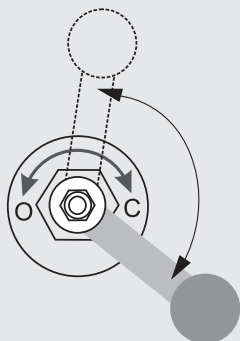

Valve with handwheel

Open anticlockwise

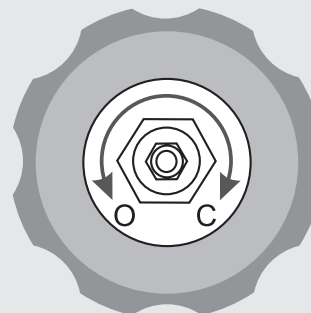

Ball-check valve

The ball-check valve should prevent any major spillage from the glass level gauge in the event of any glass or mica breakage or other sizable leakage. For this purpose there is, under the valve seat, a ball within a recess. As soon as the indicator starts to leak, the incipient flow lifts the ball from the recess and forces it against the valve seat (pressure > 0.5 bar). In this way, the flow is sharply reduced. The closing of the valve presses the ball back into its starting position.

Illustration of the ball-check valve principle

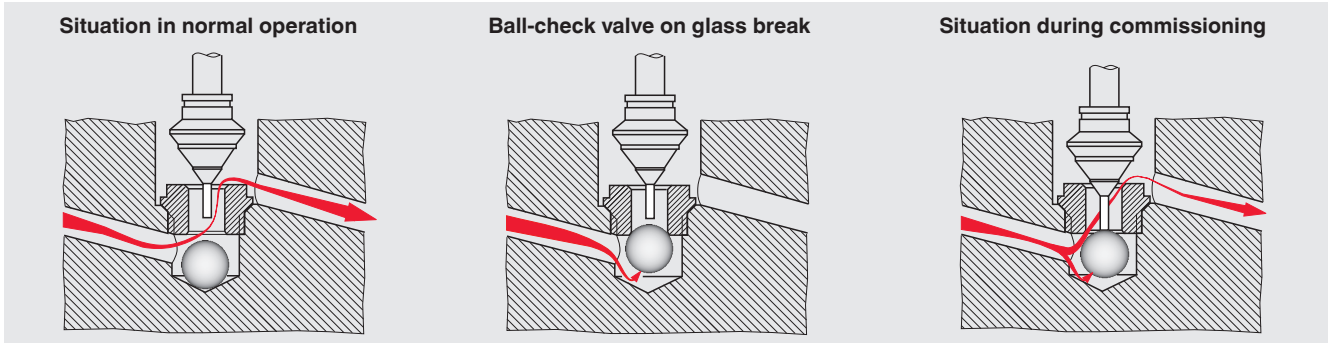

Model overview

Glass level gauge	Material	Display	Max. pressure in bar	Temperature range in °C	Glass size	Number of segments
Refl x indicator						
"Carbon-Line" version, model LGG-RP	Steel A350LF2	Sight glass	100	-40 ... +300	4 ... 9	1 ... 5
Compact version with side pieces, model LGG-E	Steel 1.0460/1.0570	Sight glass	40	-10 ... +300	2 ... 11	1 ... 3
Standard version, model LGG-RE	Steel 1.0570 (A350LF2)	Sight glass	160	-10 ... +300	2 ... 11	1 ... 5
	Stainless steel 1.4404 (316L)			-196 ... +300		
High-pressure version, model LGG-RI	Steel 1.5415 (15Mo3)	Sight glass	250	-10 ... +100	2 ... 9	1 ... 5
	Stainless steel 1.4404 (316L)			-196 ... +100		
Weld-in version, model LGG-WR	Steel 1.0570 (A350LF2)	Sight glass	40	-10 ... +300	2 ... 9	1
	Stainless steel 1.4404 (316L)			-196 ... +300		
Transparent indicator						
"Carbon-Line" version, model LGG-TP	Steel A350LF2	Glass (mica)	100	-40 ... +300	4 ... 9	1 ... 5
Standard version, model LGG-TE	Steel 1.0570 (A350LF2)	Glass (mica)	160	-10 ... +300	2 ... 11	1 ... 5
	Stainless steel 1.4404 (316L)			-196 ... +300		
High-pressure version, model LGG-TI	Steel 1.5415 (15Mo3)	Glass (mica)	250	-10 ... +100	2 ... 9	1 ... 5
	Stainless steel 1.4404 (316L)			-196 ... +100		
Superheated steam version, model LGG-T3	Steel 1.5415 (15Mo3)	Glass + mica	160	-10 ... +100	2 ... 9	1 ... 5
	Stainless steel 1.4404 (316L)			-196 ... +300		
Weld-in version, model LGG-WT	Steel 1.0570 (A350LF2)	Glass (mica)	40	-10 ... +300	2 ... 9	1
	Stainless steel 1.4404 (316L)			-196 ... +300		
Glass tube, standard, model LGG-GA	Brass	Glass tube 13 mm	10	-10 ... +120	110 ... 1,200 mm	1
	Stainless steel 1.4571 (316Ti)			-10 ... +200		
Glass tube, for large lengths with interposing glass-holder, model LGG-GB	Stainless steel 1.4404 (316L)	Glass tube 16 mm	25	-10 ... +200	150 ... 4,500 mm	1 ... 3
Refraction indicator						
Highest-pressure version, model LGG-M	Steel 1.5415 (15Mo3)	Mica	160/250	-10 ... +374	2 ... 11	1 ... 9

Examples

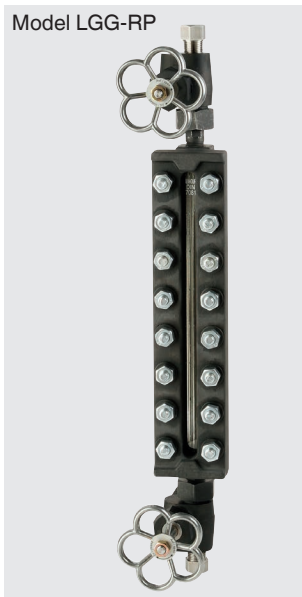

Model overview of valve heads

Valve head	Material		Max. pressure in bar	Operation	Ball-check valve	Mount	Thru-way
	Valve body	Head piece					
Glass tube fitting with handwheel, model LGV-01	Stainless steel	Stainless steel	PN 250	Handwheel	Yes	Top, bottom	Offset
Glass tube fitting with quick closing lever, model LGV-03	Stainless steel	Stainless steel	PN 100	Quick closing lever	Yes	Top, bottom	Offset
Compact glass tube fitting without valve, model LGV-04	Stainless steel	Stainless steel	PN 10	Handwheel	No	Top, bottom	Angled
Glass tube fitting compact with handwheel, model LGV-05	<ul style="list-style-type: none"> ■ Brass ■ Stainless steel 	Without	PN 10	Without	No	Top, bottom	Angled
Double valve, model LGV-18	Steel 15Mo3	Stainless steel	PN 160	Double handwheel/ double lever	Yes	Lateral	Angled
Double valve, high pressure, model LGV-19	Steel 15Mo3	Stainless steel	PN 250	Double handwheel/ double lever	Yes	Lateral	Angled
Forged valve with handwheel, model LGV-33	Steel A350LF2, nitrocarburised	Stainless steel	PN 250	Handwheel	Yes	Top, bottom	Offset
Forged valve with quick closing lever, model LGV-38	Steel A350LF2, nitrocarburised	Stainless steel	PN 100	Quick closing lever	Yes	Top, bottom	Offset
Straight valve with handwheel, model LGV-51	<ul style="list-style-type: none"> ■ Steel ■ Sstainless steel 	Stainless steel	PN 250	Handwheel	Yes	Lateral, back	Straight
Angled valve with handwheel, model LGV-52	<ul style="list-style-type: none"> ■ Steel ■ Sstainless steel 	Stainless steel	PN 250	Handwheel	Yes	Lateral	Angled
Offset valve with handwheel, model LGV-53	<ul style="list-style-type: none"> ■ Steel ■ Sstainless steel 	Stainless steel	PN 250	Handwheel	Yes	Top, bottom	Offset
Straight valve with quick closing lever, model LGV-56	<ul style="list-style-type: none"> ■ Steel ■ Sstainless steel 	Stainless steel	PN 100	Quick closing lever	Yes	Lateral, back	Straight
Angled valve with quick closing lever, model LGV-57	<ul style="list-style-type: none"> ■ Steel ■ Sstainless steel 	Stainless steel	PN 100	Quick closing lever	Yes	Lateral	Angled
Offset valve with quick closing lever, model LGV-58	<ul style="list-style-type: none"> ■ Steel ■ Sstainless steel 	Stainless steel	PN 100	Quick closing lever	Yes	Top, bottom	Offset

Examples

Model LGV-33



Model LGV-57



Model LGV-51



Valve head arrangement

The valve arrangement is always specified in relation to the viewing direction.

■ Rotatable field of view

Offset valve
Top and bottom mount

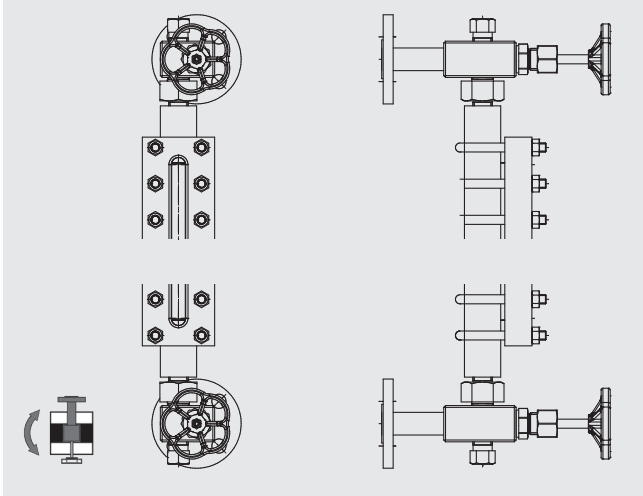

■ Fixed field of view

Straight valve
Left mount (lateral)

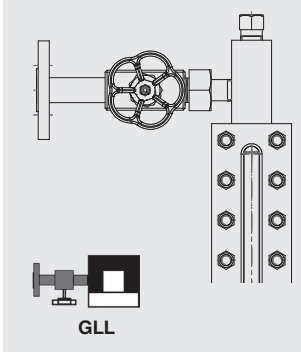

Straight valve
Back mount, left-hand

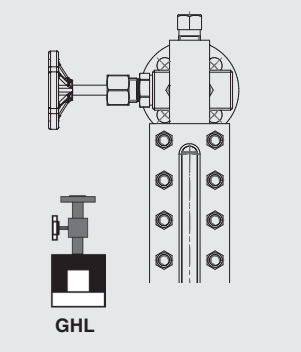

Straight valve
Back mount, right-hand

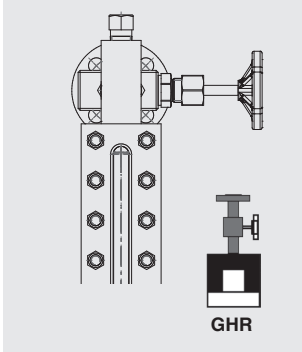

Straight valve
Right mount (lateral)

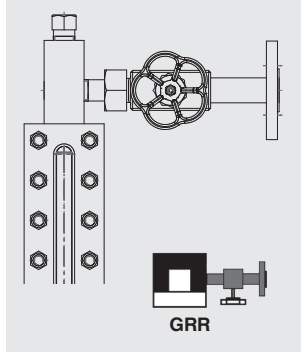

Angled valve
Left mount (lateral)

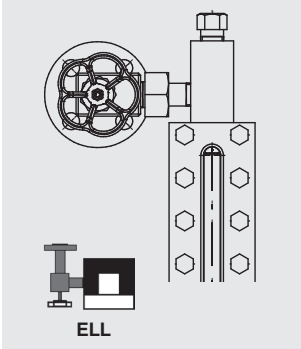

Angled valve
Back mount, left-hand

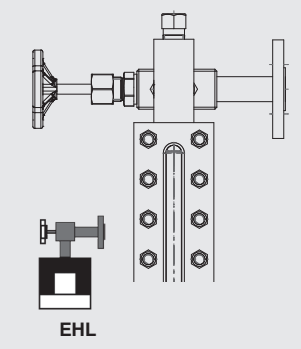

Angled valve
Back mount, right-hand

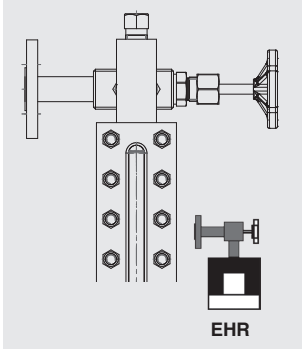

Angled valve
Right mount (lateral)

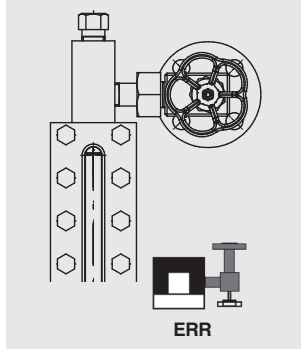

Glass level gauge, refl x, "Carbon-Line" version Model LGG-RP

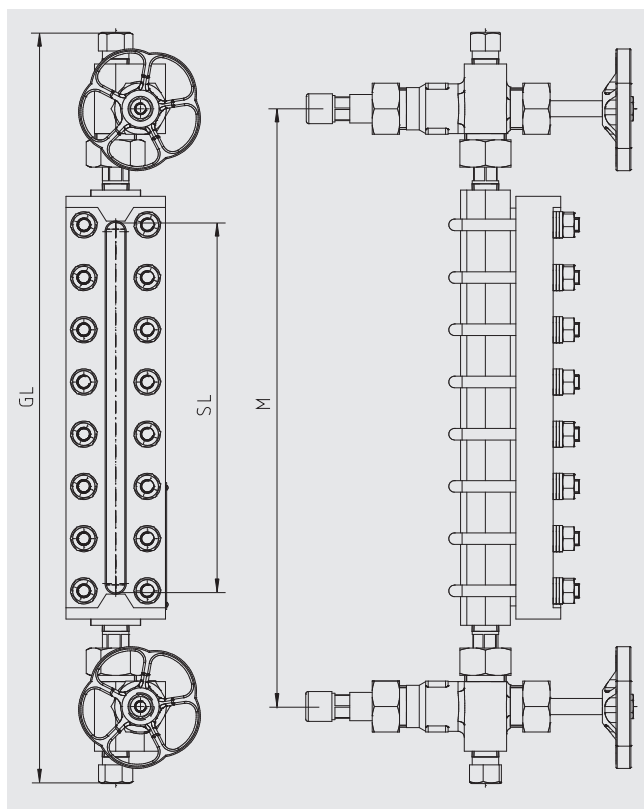

Valve arrangement

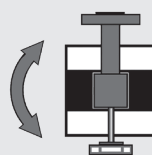

Specification	
Material	Steel A350 LF2, nitrocarburised
Gauge body	40 x 40 mm, forged
Cover	80 x 30 mm, forged
Sight glass	Borosilicate, reflex per DIN 7081
Max. operating pressure	100 bar ¹⁾
Temperature range	-40 ... +243 °C (steam) -40 ... +280 °C
Process connections	<ul style="list-style-type: none"> ■ Male thread 1/2 NPT, 3/4 NPT ■ Weld stub 1/2", 3/4" ■ Flange DIN/EN: DN 15 ... 50, PN 16 ... 100 ■ Flange ANSI: 1/2 ... 2", class 150 ... 600
Centre-to-centre distance M	Freely selectable, min. visible length SL + 180 mm
Vent	Plug 1/2 NPT (option: Valve)
Drain	Plug 1/2 NPT (option: Valve)
Glass size	4 ... 9
Number of segments	1 ... 5
Suitable valve heads	
Handwheel	Model LGV-33 (PN 250)
Quick closing lever	Model LGV-38 (PN 100)

1) Depending on the temperature, the material properties must be observed

Glass level gauge, refl x, compact version with side pieces Model LGG-E

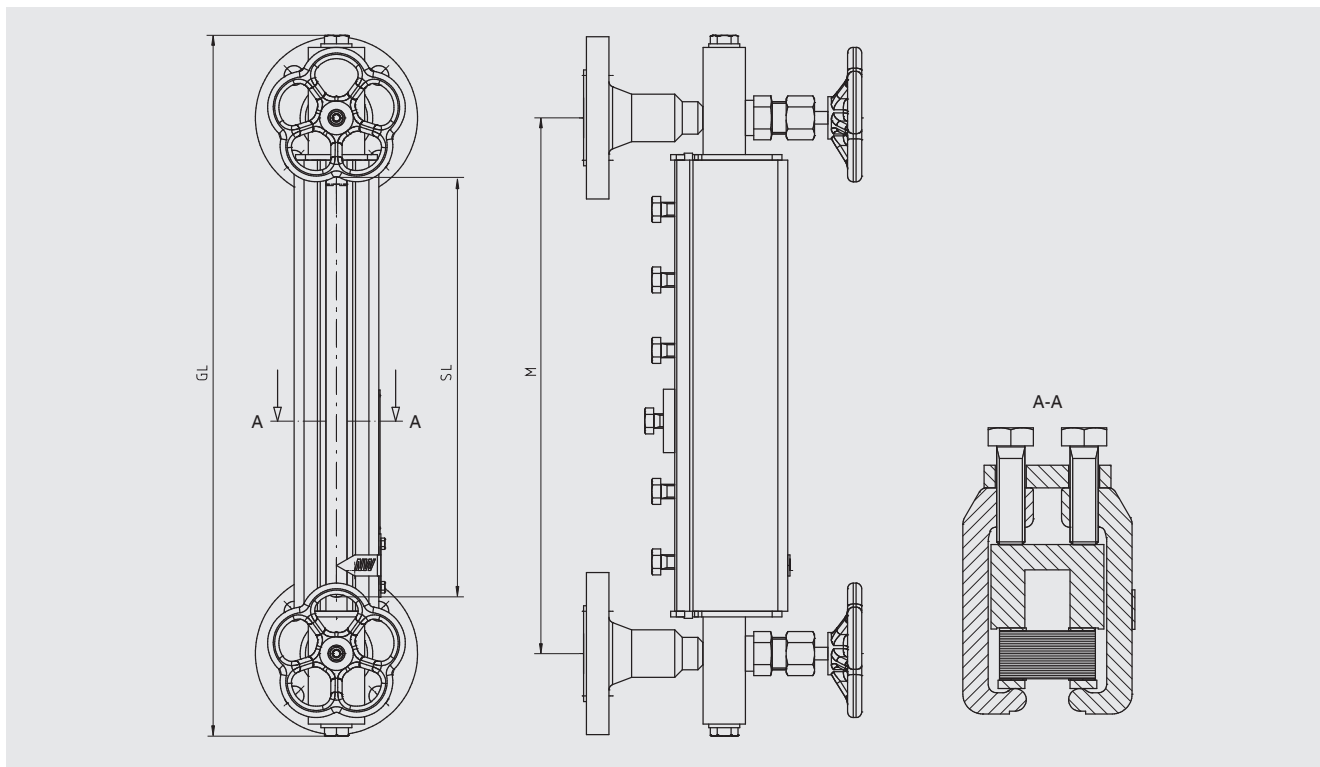

Specification	
Material	Steel 1.0460, 1.0570
Gauge body	40 x 30 mm, machined
Cover	Clamping through side components, hinged
Sight glass	Borosilicate, reflex per DIN 7081
Max. operating pressure	40 bar ¹⁾
Temperature range	-10 ... +243 °C (steam)
Process connections	<ul style="list-style-type: none"> ■ Flange DIN/EN: DN 15 ... 50, PN 16 ... 40 ■ Flange ANSI: 1/2 ... 2", class 150 ... 300
Centre-to-centre distance M	Freely selectable, min. visible length SL + 80 mm
Vent	Plug G 3/8 (option: Valve, ball valve)
Drain	Plug G 3/8 (option: Valve, ball valve)
Glass size	2 ... 11
Number of segments	1 ... 3
Suitable valve heads	Integrated, with ball-check valve, mounting components from stainless steel

1) Depending on the temperature, the material properties must be observed

Valve arrangement

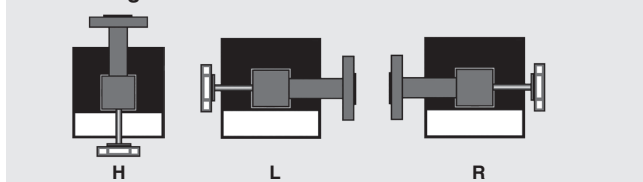

Glass level gauge, refl x, standard version

Model LGG-RE

Version with valve head, lateral, model LGV-52

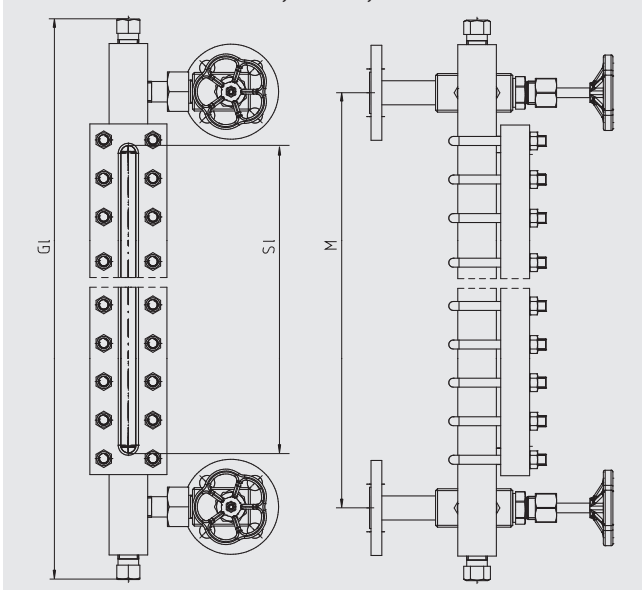

Version with valve head, top/bottom, model LGV-53

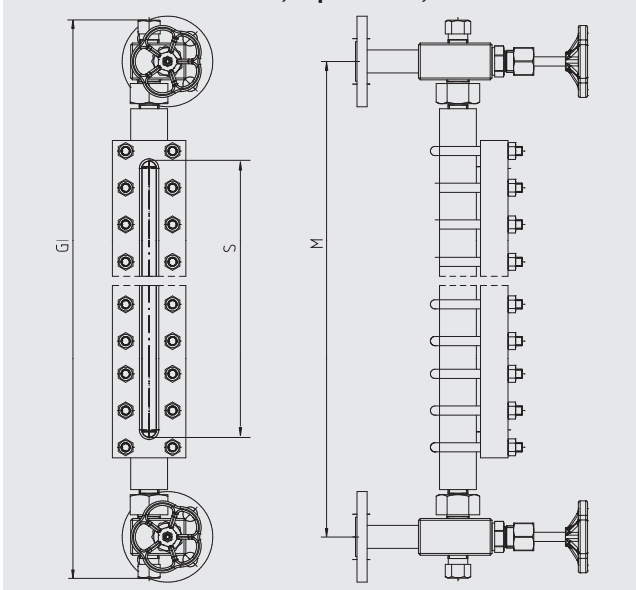

Specification	Steel version	Stainless steel version
Material	Steel 1.0570, A350 LF2	Stainless steel 1.4404 (316L)
Gauge body	40 x 40 mm, machined	
Cover	<ul style="list-style-type: none"> ■ 80 x 30 mm, forged (PN 40, size 4 ... 9) ■ 80 x 30 mm, machined (PN 40) ■ 80 x 40 mm, machined (PN 100, PN 160) 	<ul style="list-style-type: none"> ■ 80 x 30 mm, machined (PN 40) ■ 80 x 40 mm, machined (PN 100, PN 160)
Sight glass	Borosilicate, reflex per DIN 7081	
Max. operating pressure	40 bar, 100 bar, 160 bar ¹⁾	
Temperature range	-10 ... +243 °C (steam) -10 ... +300 °C	-196 ... +243 °C (steam) -196 ... +300 °C
Process connections	<ul style="list-style-type: none"> ■ Male thread 1/2 NPT, 3/4 NPT ■ Weld stub 1/2", 3/4" ■ Flange DIN/EN: DN 15 ... 50, PN 16 ... 160 ■ Flange ANSI: 1/2 ... 2", class 150 ... 900 	
Centre-to-centre distance M	<ul style="list-style-type: none"> ■ Freely selectable, min. visible length SL + 180 mm (with mounted valve heads model LGV-33, LGV-38, LGV-53, LGV-58) ■ Freely selectable, min. visible length SL + 80 mm (with mounted valve heads model LGV-51, LGV-52, LGV-56, LGV-57) ■ Special version, visible length = M (with mounted valve heads model LGV-51, LGV-52, LGV-56, LGV-57) 	
Vent	Plug G 3/8 (option: Weld stub, flange, valve or ball valve)	
Drain	Plug G 3/8 (option: Weld stub, flange, valve or ball valve)	
Glass size	2 ... 11	
Number of segments	1 ... 5 (more on request)	
Suitable valve heads		
Handwheel	Model LGV-33, LGV-51, LGV-52, LGV-53 (PN 250)	Model LGV-51, LGV-52, LGV-53 (PN 250)
Quick closing lever	Model LGV-38, LGV-56, LGV-57, LGV-58 (PN 100)	Model LGV-56, LGV-57, LGV-58 (PN 100)

Other materials on request

¹⁾ Depending on the temperature, the material properties must be observed

Valve arrangement
Model LGV-51, LGV-56

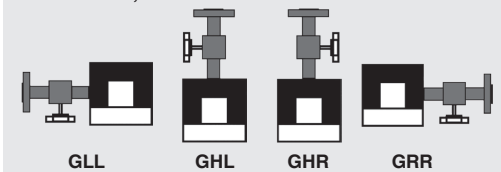

Model LGV-52, LGV-57

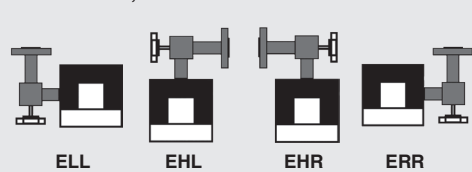

Model LGV-33, LGV-38,
LGV-53, LGV-58

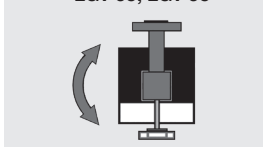

Glass level gauge, refl x, high-pressure version Model LGG-RI

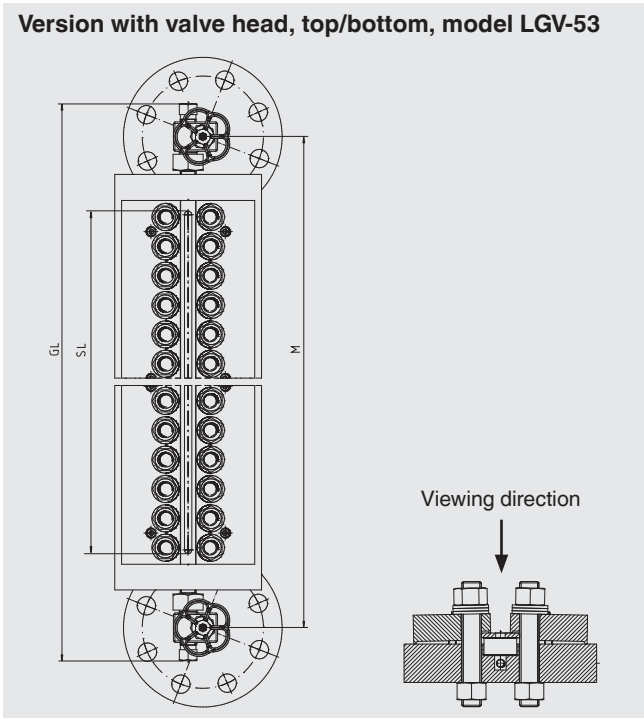
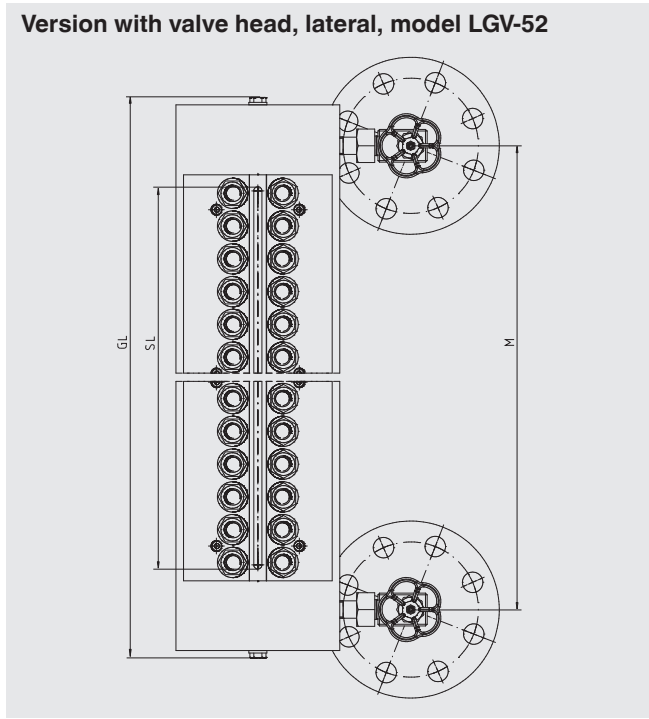

Specification	Steel version	Stainless steel version
Material	Steel 1.5415 (15Mo3)	Stainless steel 1.4404 (316L)
Gauge body	140 x 40 mm, machined	
Cover	Pressure frame	
Sight glass	Borosilicate, reflex per DIN 7081	
Max. operating pressure	250 bar ¹⁾	
Temperature range	-10 ... +100 °C	-196 ... +100 °C
Process connections	<ul style="list-style-type: none"> ■ Male thread 1/2 NPT, 3/4 NPT ■ Weld stub 1/2", 3/4" ■ Flange DIN/EN: DN 15 ... 50, PN 16 ... 250 ■ Flange ANSI: 1/2 ... 2", class 150 ... 1,500 	
Centre-to-centre distance M	<ul style="list-style-type: none"> ■ Freely selectable, min. visible length SL + 180 mm (with mounted valve head model LGV-53) ■ Freely selectable, visible length SL ≤ M (with mounted valve heads model LGV-51, LGV-52) 	
Vent	Plug G 3/8 (option: Weld stub, flange, valve or ball valve)	
Drain	Plug G 3/8 (option: Weld stub, flange, valve or ball valve)	
Glass size	2 ... 9	
Number of segments	1 ... 5	
Suitable valve heads		
Handwheel	Model LGV-51, LGV-52, LGV-53	

Other materials on request

1) Depending on the temperature, the material properties must be observed

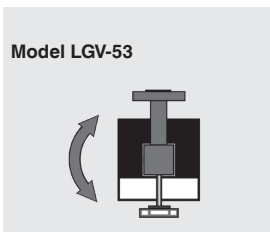
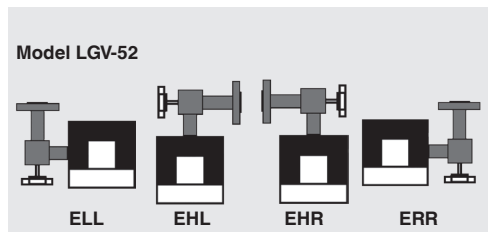
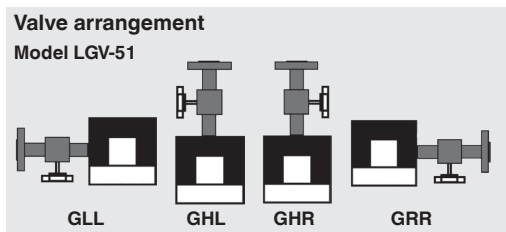

Glass level gauge, refl x, weld-in version Model LGG-WR

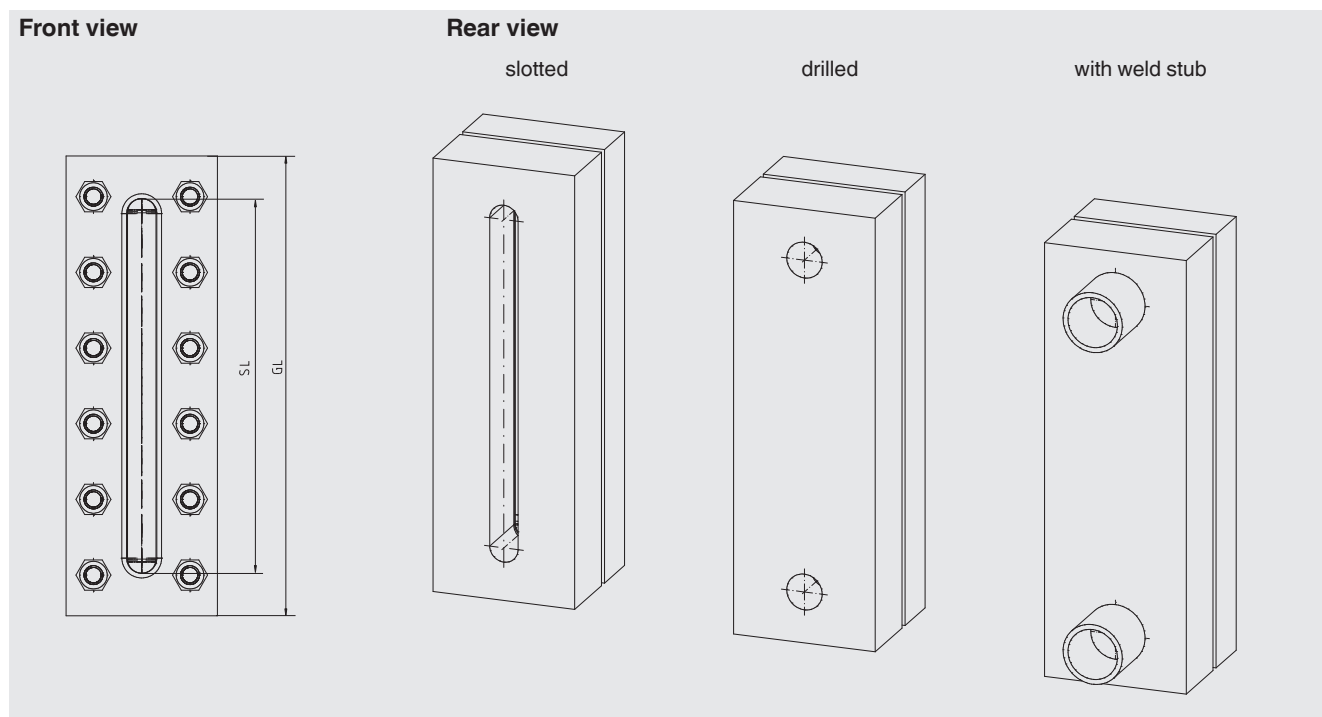

Specification	Steel version	Stainless steel version
Material	Steel 1.0570	Stainless steel 1.4404 (316L)
Gauge body	40 x 40 mm, machined	
Cover	40 x 40 mm, machined	
Sight glass	Borosilicate, reflex per DIN 7081	
Max. operating pressure	40 bar ¹⁾ (display must be included in the pressure test for the vessel)	
Temperature range	-10 ... +243 °C (steam) -10 ... +300 °C	-196 ... +243 °C (steam) -196 ... +300 °C
Overall length GL	Visible length SL + 43 mm	
Glass size	2 ... 9 (larger on request)	
Number of segments	1	

Other materials on request

1) Depending on the temperature, the material properties must be observed

Glass level gauge, transparent, "Carbon-Line" version Model LGG-TP

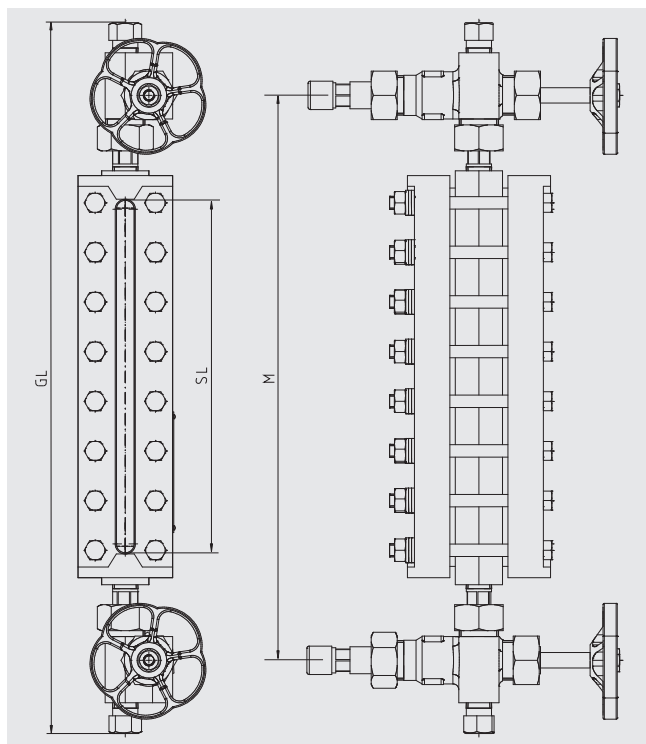

Specification	
Material	Steel A350 LF2, nitrocarburised
Gauge body	40 x 40 mm, forged
Cover	80 x 34 mm, forged
Sight glass	Borosilicate, transparent per DIN 7081 (option: Mica design)
Max. operating pressure	100 bar ¹⁾
Temperature range	-40 ... +243 °C (steam, without mica design) -40 ... +300 °C (steam, with mica design) -40 ... +300 °C
Process connections	<ul style="list-style-type: none"> ■ Male thread 1/2 NPT, 3/4 NPT ■ Weld stub 1/2", 3/4" ■ Flange DIN/EN DN 15 ... 50, PN 16 ... 100 ■ Flange ANSI 1/2 ... 2", class 150 ... 600
Centre-to-centre distance M	Freely selectable, min. visible length SL + 180 mm
Vent	Plug 1/2 NPT (option: Valve)
Drain	Plug 1/2 NPT (option: Valve)
Glass size	4 ... 9
Number of segments	1 ... 5
Suitable valve heads	
Handwheel	Model LGV-33 (PN 250)
Quick closing lever	Model LGV-38 (PN 100)

Other materials on request

¹⁾ Depending on the temperature, the material properties must be observed

Valve arrangement

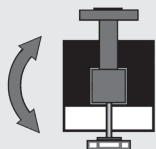

Glass level gauge, transparent, standard version Model LGG-TE

Version with valve head, lateral, model LGV-52

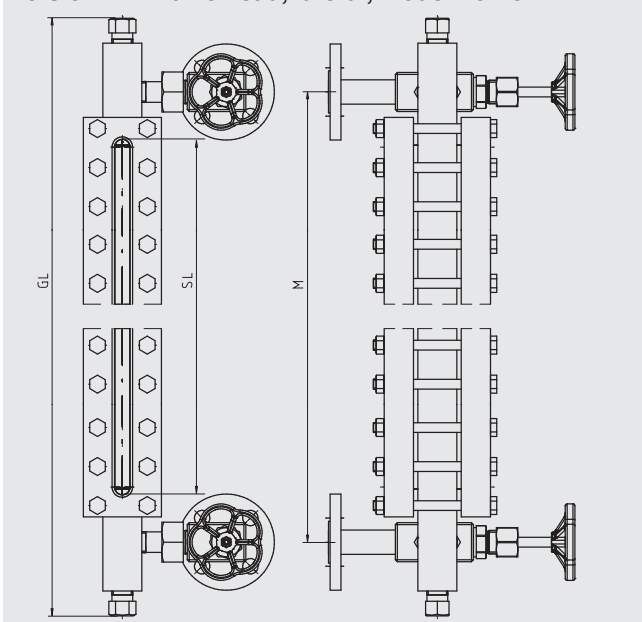

Version with valve head, top/bottom, model LGV-53

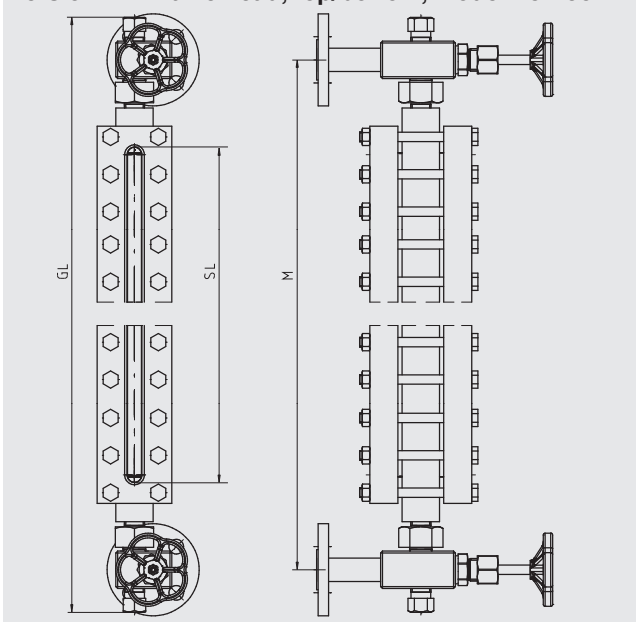

Specification	Steel version	Stainless steel version
Material	Steel 1.0570, A350 LF2	Stainless steel 1.4404 (316L)
Gauge body	40 x 40 mm, machined	
Cover	80 x 30 mm, forged (PN 40, size 4 ... 9) 80 x 30 mm, machined (PN 40) 80 x 40 mm, machined (PN 100, PN 160)	80 x 30 mm, machined (PN 40) 80 x 40 mm, machined (PN 100, PN 160)
Sight glass	Borosilicate, transparent per DIN 7081 (option: Mica design)	
Max. operating pressure	40 bar, 100 bar, 160 bar ¹⁾	
Temperature range	-10 ... +243 °C (steam, without mica design) -10 ... +300 °C (steam, with mica design) -10 ... +300 °C	-196 ... +243 °C (steam, without mica design) -196 ... +300 °C (steam, with mica design) -196 ... +300 °C
Process connections	Male thread 1/2 NPT, 3/4 NPT Weld stub 1/2", 3/4" Flange DIN/EN DN 15 ... 50, PN 16 ... 160 Flange ANSI 1/2 ... 2", class 150 ... 900	
Centre-to-centre distance M	<ul style="list-style-type: none"> ■ Freely selectable, min. visible length SL + 180 mm (with mounted valve heads model LGV-33, LGV-38, LGV-53, LGV-58) ■ Freely selectable, min. visible length SL + 80 mm (with mounted valve heads model LGV-51, LGV-52, LGV-56, LGV-57) ■ Special version, visible length = M (with mounted valve heads model LGV-51, LGV-52, LGV-56, LGV-57) 	
Vent	Plug G 3/8 (option: Weld stub, flange, valve or ball valve)	
Drain	Plug G 3/8 (option: Weld stub, flange, valve or ball valve)	
Glass size	2 ... 11	
Number of segments	1 ... 5 (more on request)	
Suitable valve heads		
Handwheel	Model LGV-33, LGV-51, LGV-52, LGV-53 (PN 250)	Model LGV-51, LGV-52, LGV-53 (PN 250)
Quick closing lever	Model LGV-38, LGV-56, LGV-57, LGV-58 (PN 100)	Model LGV-56, LGV-57, LGV-58 (PN 100)

Other materials on request

¹⁾ Depending on the temperature, the material properties must be observed

Valve arrangement

Model LGV-51, LGV-56

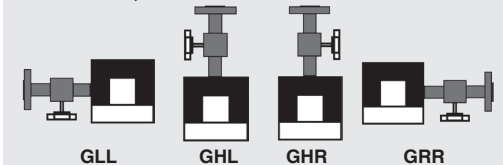

Model LGV-52, LGV-57

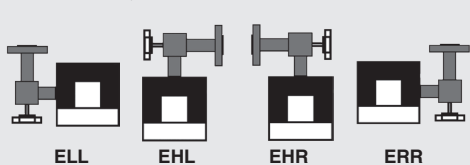

Model LGV-33, LGV-38,
LGV-53, LGV-58

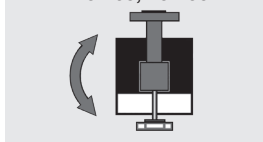

Glass level gauge, transparent, high-pressure version Model LGG-TI

Version with valve head, lateral, model LGV-52

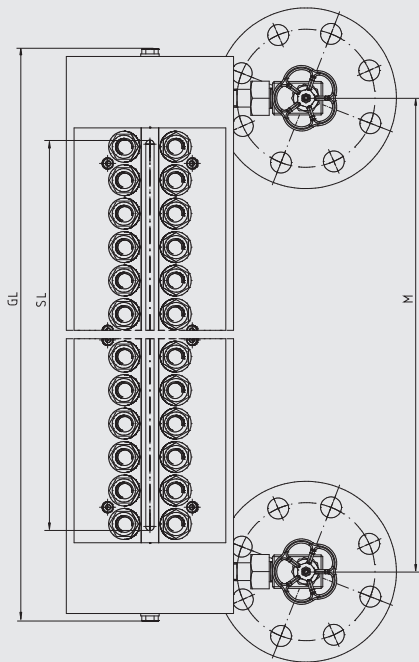

Version with valve head, top/bottom, model LGV-53

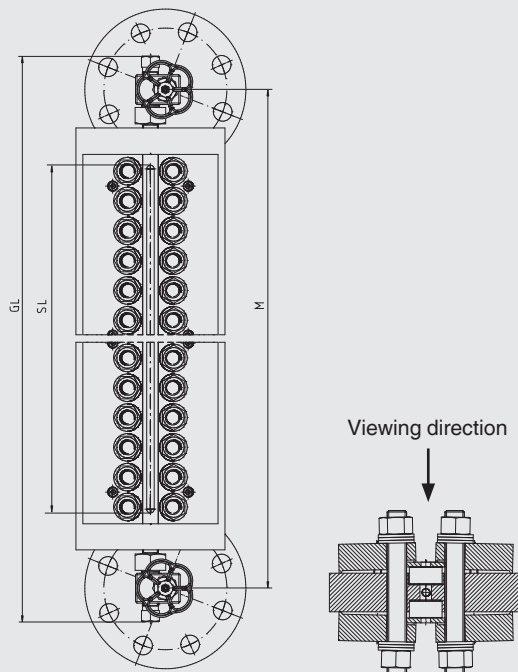

Specification	Steel version	Stainless steel version
Material	Steel 1.5415 (15Mo3)	Stainless steel 1.4404 (316L)
Gauge body	140 x 40 mm, machined	
Cover	Pressure frame	
Sight glass	Borosilicate, transparent per DIN 7081	
Max. operating pressure	250 bar ¹⁾	
Temperature range	-10 ... +100 °C	-196 ... +100 °C
Process connections	<ul style="list-style-type: none"> ■ Male thread 1/2 NPT, 3/4 NPT ■ Weld stub 1/2", 3/4" ■ Flange DIN/EN DN 15 ... 50, PN 16 ... 250 ■ Flange ANSI 1/2 ... 2", class 150 ... 1,500 	
Centre-to-centre distance M	<ul style="list-style-type: none"> ■ Freely selectable, min. visible length SL + 180 mm (with mounted valve head model LGV-53) ■ Freely selectable, visible length SL ≤ M (with mounted valve heads model LGV-51, LGV-52) 	
Vent	Plug G 3/8 (option: Weld stub, flange, valve or ball valve)	
Drain	Plug G 3/8 (option: Weld stub, flange, valve or ball valve)	
Glass size	2 ... 9	
Number of segments	1 ... 5	
Suitable valve heads		
Handwheel	Model LGV-51, LGV-52, LGV-53	

Other materials on request

1) Depending on the temperature, the material properties must be observed

Valve arrangement
Model LGV-51

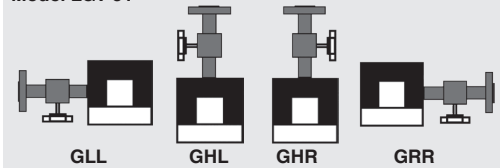

Model LGV-52

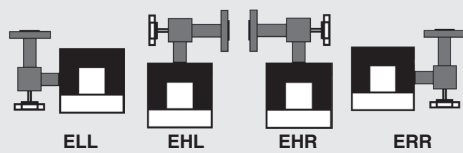

Model LGV-53

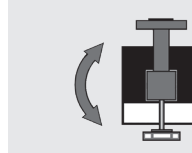

Glass level gauge, transparent, superheated steam version Model LGG-T3

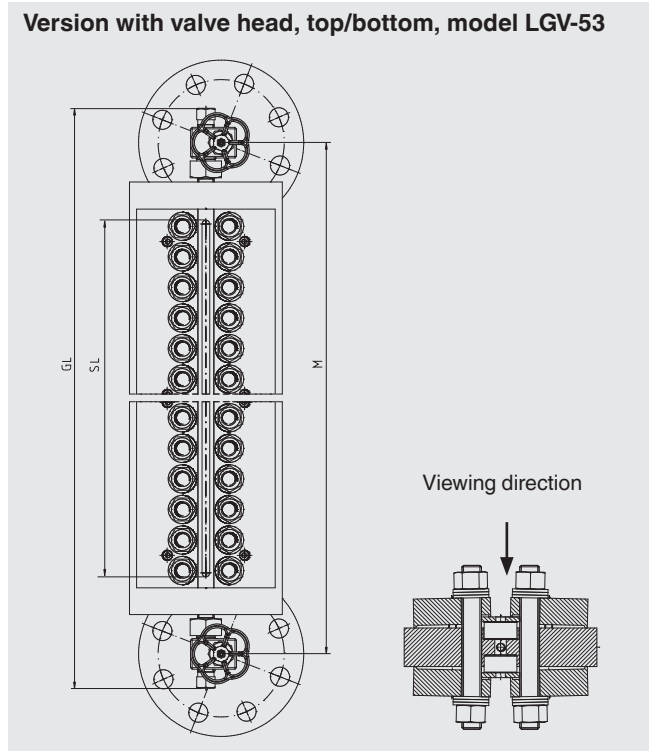
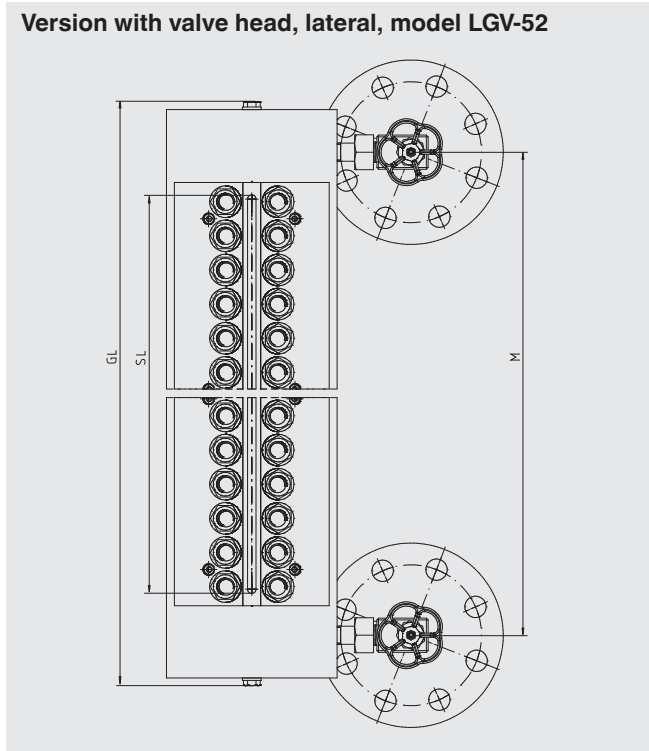

Specification	Steel version	Stainless steel version
Material	Steel 1.5415 (15Mo3)	Stainless steel 1.4404 (316L)
Gauge body	140 x 40 mm, machined	
Cover	Pressure frame	
Sight glass	Borosilicate, transparent per DIN 7081 (with mica design)	
Max. operating pressure	160 bar ¹⁾	
Temperature range	-10 ... +300 °C	-196 ... +300 °C
Process connections	<ul style="list-style-type: none"> ■ Male thread G 1/2, G 3/4, 1/2 NPT, 3/4 NPT ■ Weld stub 1/2", 3/4" ■ Flange DIN/EN DN 15 ... 50, PN 16 ... 100 ■ Flange ANSI 1/2 ... 2", class 150 ... 600 	
Centre-to-centre distance M	<ul style="list-style-type: none"> ■ Freely selectable, min. visible length SL + 180 mm (with mounted valve head model LGV-53) ■ Freely selectable, visible length SL ≤ M (with mounted valve heads model LGV-51, LGV-52) 	
Vent	Plug G 3/8 (option: Weld stub, flange, valve or ball valve)	
Drain	Plug G 3/8 (option: Weld stub, flange, valve or ball valve)	
Glass size	2 ... 9	
Number of segments	1 ... 5	
Suitable valve heads		
Handwheel	Model LGV-51, LGV-52, LGV-53	

Other materials on request

1) Depending on the temperature, the material properties must be observed

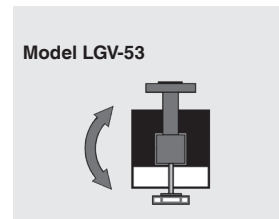
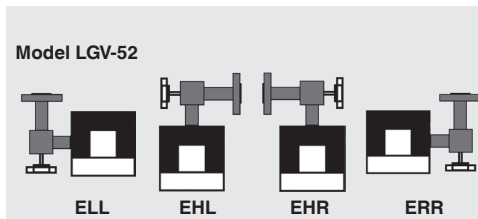
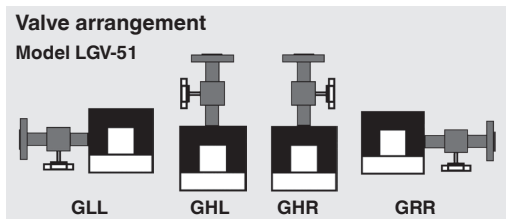

Glass level gauge, transparent, weld-in version Model LGG-WT

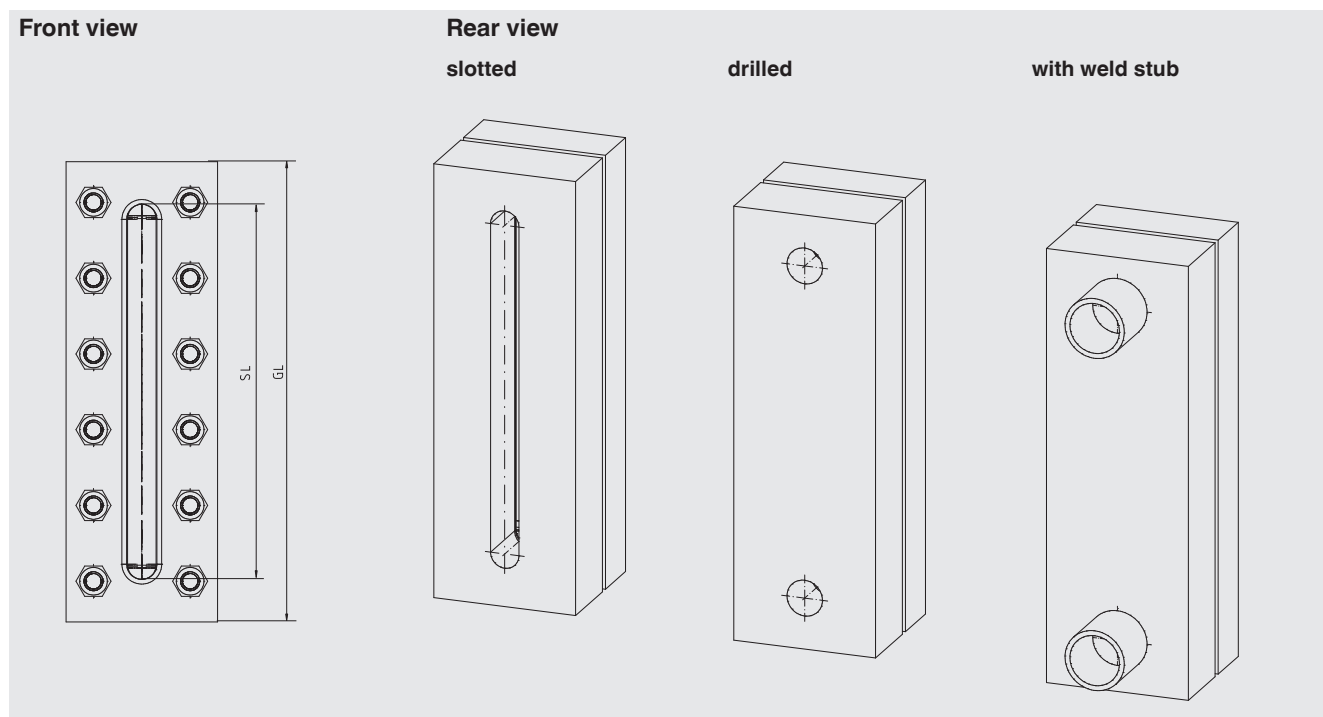

Specification	Steel version	Stainless steel version
Material	Steel 1.0570	Stainless steel 1.4404 (316L)
Gauge body	80 x 40 mm, machined	
Cover	<ul style="list-style-type: none"> ■ 80 x 30 mm, forged (size 4 ... 9) ■ 80 x 30 mm, machined 	80 x 30 mm, machined
Sight glass	Borosilicate, transparent per DIN 7081 (option: Mica design)	
Max. operating pressure	40 bar ¹⁾ (display must be included in the pressure test for the vessel)	
Temperature range	<ul style="list-style-type: none"> -10 ... +243 °C (steam, without mica design) -10 ... +300 °C (steam, with mica design) -10 ... +300 °C 	<ul style="list-style-type: none"> -196 ... +243 °C (steam, without mica design) -196 ... +300 °C (steam, with mica design) -196 ... +300 °C
Overall length GL	Visible length SL + 43 mm	
Glass size	2 ... 9 (larger on request)	
Number of segments	1	

1) Depending on the temperature, the material properties must be observed

Other materials on request

Glass level gauge, glass tube, standard Model LGG-GA

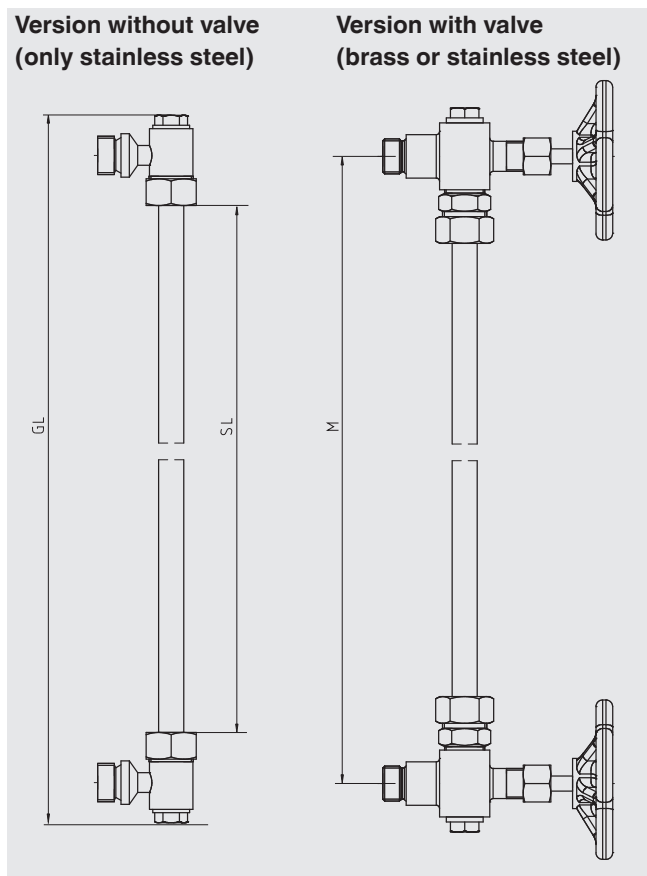

Specification	Version without valve	Version with valve
Material	Stainless steel 1.4571	Stainless steel 1.4571 or brass 2.0401
Sight glass	Glass tube, borosilicate, diameter 13 mm	
Max. operating pressure	10 bar ¹⁾	
Temperature range	-10 ... +80 °C (with plexi protective cover) -10 ... +150 °C (with stainless steel protection)	-10 ... +200 °C
Process connections	Male thread G 1/2 Flange DIN/EN DN 15 ... 25, PN 10	
Centre-to-centre distance M	110 ... 1,200 mm, visible length SL + 70 mm	150 ... 1,200 mm, visible length SL + 110 mm
Vent	Plug G 3/8	Plug G 1/2
Drain	Plug G 3/8	Plug G 1/2
Glass size	Centre-to-centre distance M - 20 mm	Centre-to-centre distance M - 65 mm
Number of segments	1	
Suitable valve heads		
Glass tube fitting	Model LGV-04	Model LGV-05

1) Depending on the temperature, the material properties must be observed

Other materials on request

Glass level gauge, glass tube, for large lengths with interposing glass-holder Model LGG-GB

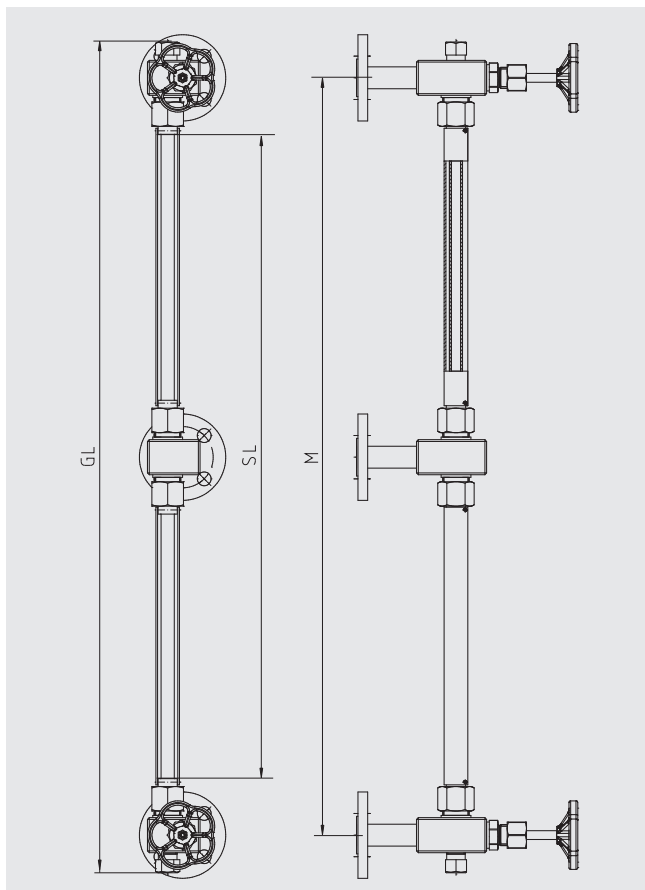

Specification

Material	Stainless steel 1.4404 (316L)
Sight glass	Glass tube, borosilicate, diameter 16 mm
Max. operating pressure	25 bar ¹⁾
Temperature range	-10 ... +200 °C
Process connections	<ul style="list-style-type: none"> ■ Male thread G 1/2 ■ Flange DIN/EN DN 15 ... 25, PN 25
Centre-to-centre distance M	150 ... 4,500 mm, visible length SL + 130 mm
Vent	Plug
Drain	Plug
Glass size	150 ... 4,500 mm (use interposing glass-holder from 1,500 mm)
Number of segments	1 ... 3
Suitable valve heads	
Handwheel	Model LGV-01
Quick closing lever	Model LGV-03

1) Depending on the temperature, the material properties must be observed

Other materials on request

Glass level gauge, refraction, highest-pressure version Model LGG-M

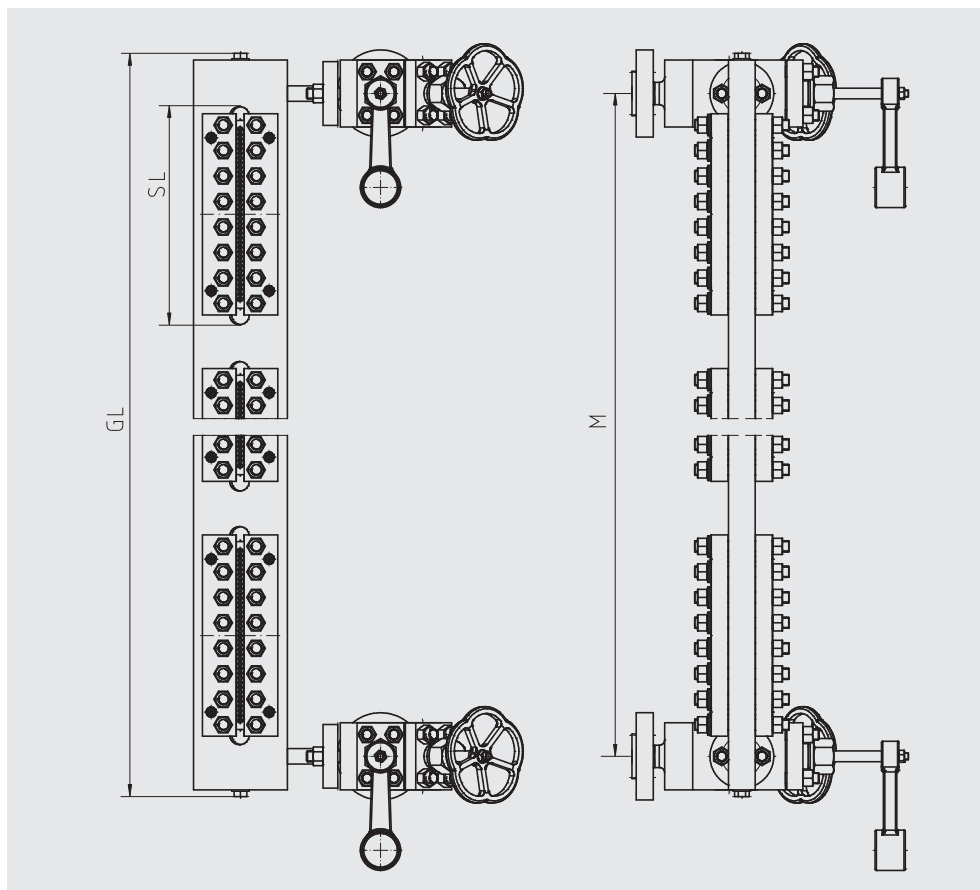

Valve arrangement
Model LGV-18, LGV-19



Specification	
Material	Steel 1.5415 (15Mo3)
Gauge body	140 x 40 mm, machined
Cover	Pressure frame
Sight glass	Mica package (sight glass separation 120 mm)
Max. operating pressure	250 bar ¹⁾
Temperature range	-10 ... +374 °C
Process connections	<ul style="list-style-type: none"> ■ Flange DIN/EN DN 15 ... 50, PN 16 ... 250 ■ Flange ANSI 1/2 ... 2", class 150 ... 2,500
Centre-to-centre distance M	Freely selectable, min. visible length SL + 80 mm
Vent	Plug G 3/8 (option: Weld stub, flange, valve or ball valve)
Drain	Plug G 3/8 (option: Weld stub, flange, valve or ball valve)
Glass size	2 ... 11
Number of segments	1 ... 9
Suitable valve heads	
Handwheel and quick closing lever	<ul style="list-style-type: none"> ■ Model LGV-19 (PN 250) ■ Model LGV-18 (PN 160)

1) Depending on the temperature, the material properties must be observed

Other materials on request

Valve heads

Model LGV-01

Glass tube fitting with handwheel

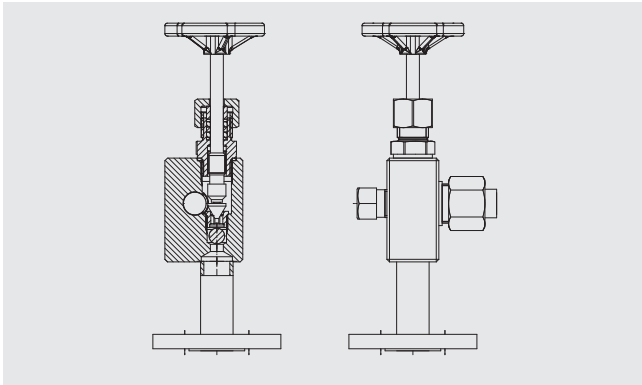

Specification	
Materials	
Valve body	Stainless steel
Head piece	Stainless steel
Construction	
Machined	
Pressure range	
PN 25	
Operation	
Handwheel	
Mount	
Top/bottom	
Connection to gauge body	
Glass tube 16	
Rotatable	
Yes	
Thru-way	
Offset	
Seat position	
Inline	
Valve stem thread	
Internal	
Drain	
Yes	
Ball-check valve	
Yes	

Model LGV-03

Glass tube fitting with quick closing lever

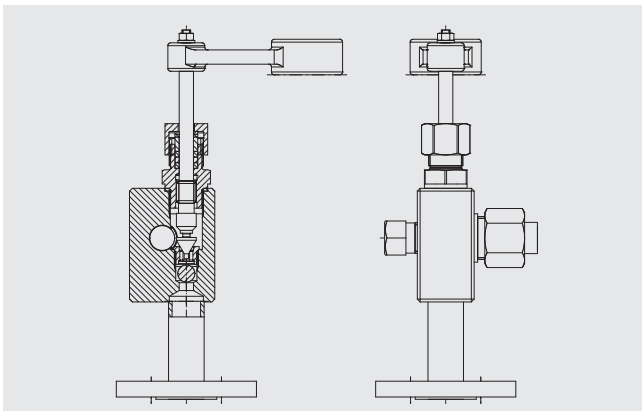

Specification	
Materials	
Valve body	Stainless steel
Head piece	Stainless steel
Construction	
Machined	
Pressure range	
PN 25	
Operation	
Quick closing lever	
Mount	
Top/bottom	
Connection to gauge body	
Glass tube 16	
Rotatable	
Yes	
Thru-way	
Offset	
Seat position	
Inline	
Valve stem thread	
Internal	
Drain	
No	
Ball-check valve	
Yes	

Model LGV-04

Compact glass tube fitting without valve

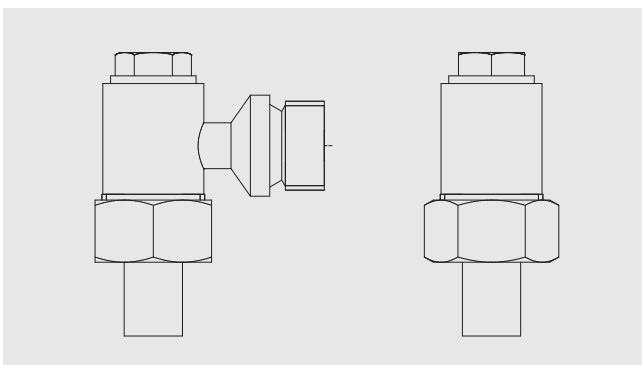

Specification	
Valve body material	Stainless steel 1.4571
Construction	
Cast	
Pressure range	
PN 25	
Operation	
Without	
Mount	
Top/bottom	
Connection to gauge body	
Glass tube 13.5	
Rotatable	
Yes	
Thru-way	
Angled	
Seat position	
Without	
Valve stem thread	
Without	
Drain	
Yes, G 3/8	
Ball-check valve	
No	

Model LGV-05
Compact glass tube fitting with handwheel

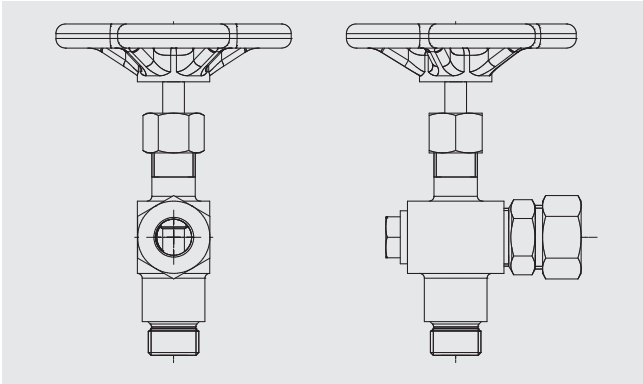

Specification	
Materials	
Valve body	<ul style="list-style-type: none"> ■ Brass 2.0401 ■ Stainless steel 1.4571
Head piece	Stainless steel
Construction	Machined
Pressure range	PN 10
Operation	Handwheel
Mount	Top/bottom
Connection to gauge body	Glass tube 13.5
Rotatable	Yes
Thru-way	Angled
Seat position	Inline
Valve stem thread	Internal
Drain	Yes, G 1/4
Ball-check valve	No

Model LGV-18
Double valve

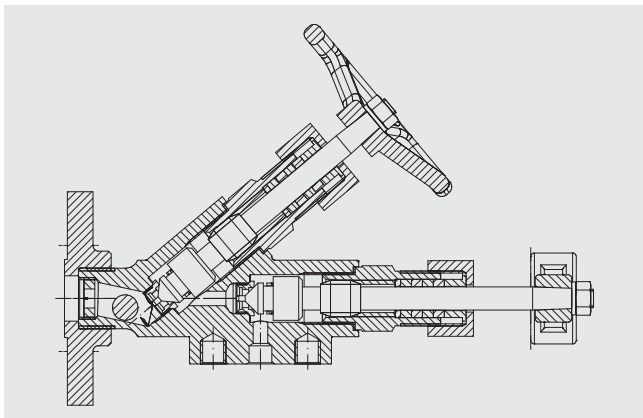

Specification	
Materials	
Valve body	Steel 15Mo3
Head piece	Stainless steel
Construction	Forged
Pressure range	PN 160
Operation	Double handwheel / lever
Mount	Lateral
Connection to gauge body	Flanged
Rotatable	No
Thru-way	Angled
Seat position	Inline
Valve stem thread	Internal
Drain	No
Ball-check valve	Yes

Model LGV-19
Double valve, high pressure

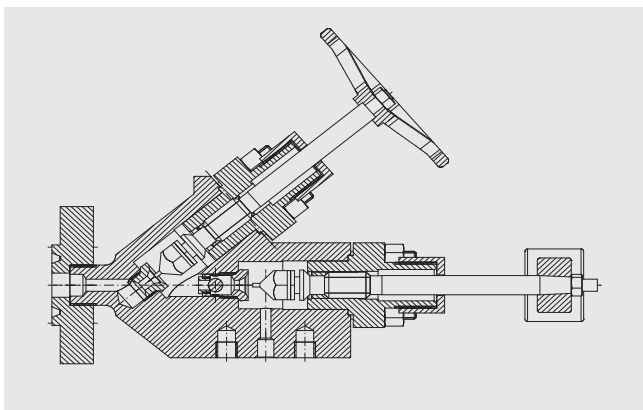

Specification	
Materials	
Valve body	Steel 15Mo3
Head piece	Stainless steel
Construction	Machined
Pressure range	PN 250
Operation	Double handwheel / lever
Mount	Lateral
Connection to gauge body	Flanged
Rotatable	No
Thru-way	Angled
Seat position	Inline
Valve stem thread	Internal
Drain	No
Ball-check valve	Yes

Model LGV-33
Forged valve with handwheel

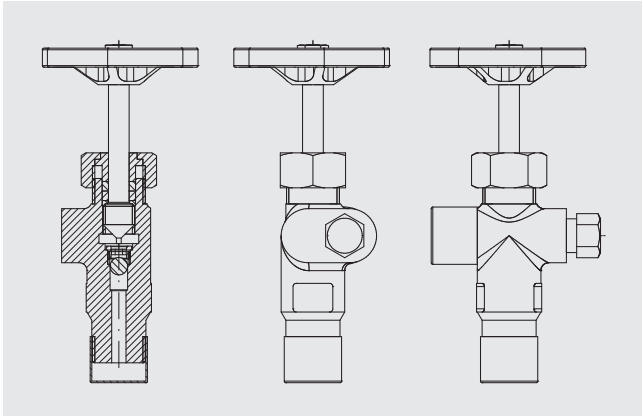

Specification	
Materials	
Valve body	Steel A350 LF2
Head piece	Stainless steel
Construction	Forged
Pressure range	PN 250
Operation	Handwheel
Mount	Top/bottom
Connection to gauge body	Screwed nipple
Rotatable	Yes
Thru-way	Offset
Seat position	Inline
Valve stem thread	Internal
Drain	Yes, 1/2 NPT
Ball-check valve	Yes

Model LGV-38
Forged valve with quick closing lever

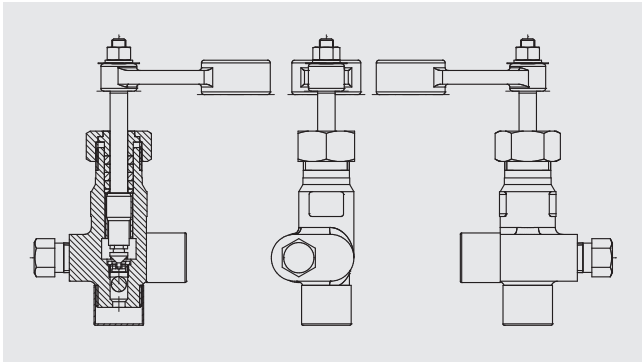

Specification	
Materials	
Valve body	Steel A350 LF2
Head piece	Stainless steel
Construction	Forged
Pressure range	PN 250
Operation	Quick closing lever
Mount	Top/bottom
Connection to gauge body	Screwed nipple
Rotatable	Yes
Thru-way	Offset
Seat position	Inline
Valve stem thread	Internal
Drain	Yes, 1/2 NPT
Ball-check valve	Yes

Model LGV-51, straight valve with handwheel

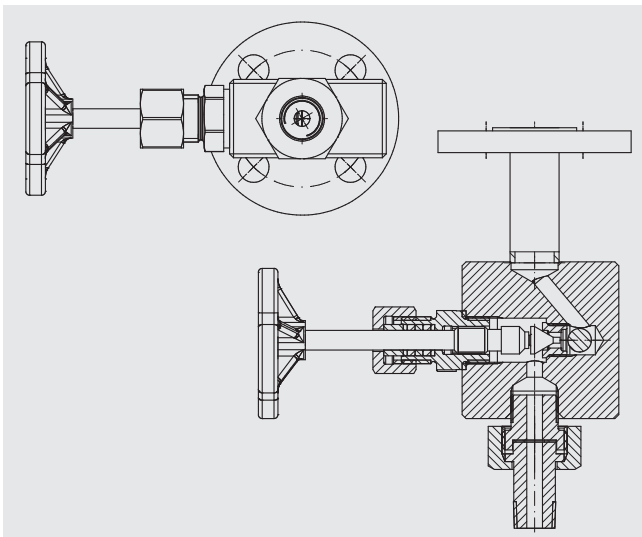

Specification	
Materials	
Valve body	Steel, stainless steel
Head piece	Stainless steel
Construction	Machined
Pressure range	PN 250
Operation	Handwheel
Mount	Lateral/back
Connection to gauge body	Screwed nipple
Rotatable	No
Thru-way	Straight
Seat position	Inline
Valve stem thread	Internal
Drain	No
Ball-check valve	Yes

Model LGV-52
Angled valve with handwheel

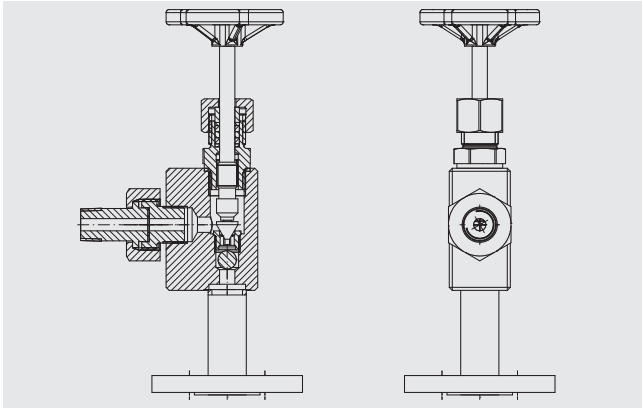

Specification	
Materials	
Valve body	Steel, stainless steel
Head piece	Stainless steel
Construction	
Construction	Machined
Pressure range	
Pressure range	PN 250
Operation	
Operation	Handwheel
Mount	
Mount	Lateral
Connection to gauge body	
Connection to gauge body	Screwed nipple
Rotatable	
Rotatable	No
Thru-way	
Thru-way	Angled
Seat position	
Seat position	Inline
Valve stem thread	
Valve stem thread	Internal
Drain	
Drain	No
Ball-check valve	
Ball-check valve	Yes

Model LGV-53
Offset valve with handwheel

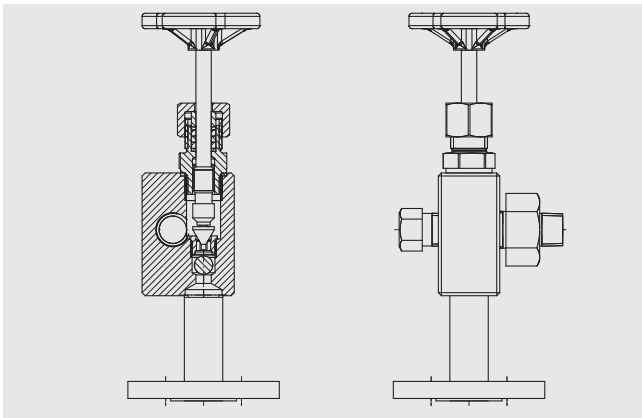

Specification	
Materials	
Valve body	Steel, stainless steel
Head piece	Stainless steel
Construction	
Construction	Machined
Pressure range	
Pressure range	PN 250
Operation	
Operation	Handwheel
Mount	
Mount	Top/bottom
Connection to gauge body	
Connection to gauge body	Screwed nipple
Rotatable	
Rotatable	Yes
Thru-way	
Thru-way	Offset
Seat position	
Seat position	Inline
Valve stem thread	
Valve stem thread	Internal
Drain	
Drain	Yes
Ball-check valve	
Ball-check valve	Yes

Model LGV-56
straight valve with quick closing lever

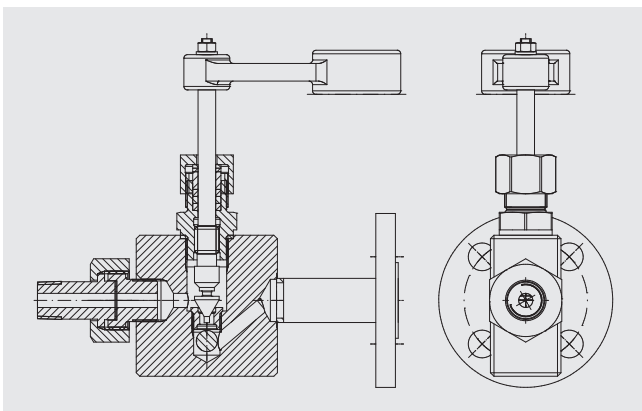

Specification	
Materials	
Valve body	Steel, stainless steel
Head piece	Stainless steel
Construction	
Construction	Machined
Pressure range	
Pressure range	PN 100
Operation	
Operation	Quick closing lever
Mount	
Mount	Lateral/back
Connection to gauge body	
Connection to gauge body	Screwed nipple
Rotatable	
Rotatable	No
Thru-way	
Thru-way	Straight
Seat position	
Seat position	Inline
Valve stem thread	
Valve stem thread	Internal
Drain	
Drain	No
Ball-check valve	
Ball-check valve	Yes

Model LGV-57
Angled valve with quick closing lever

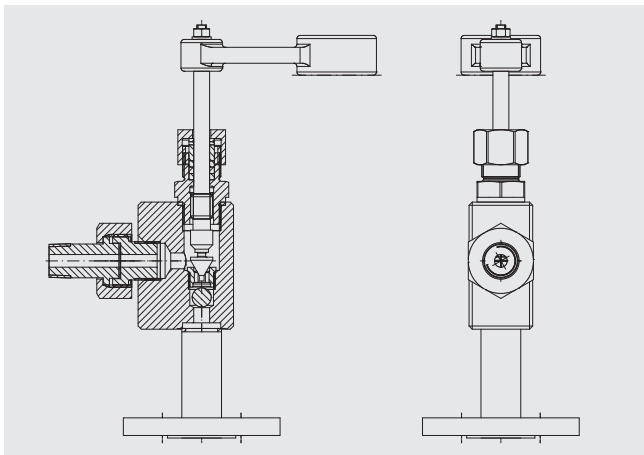

Specification	
Materials	
Valve body	Steel, stainless steel
Head piece	Stainless steel
Construction	
	Machined
Pressure range	
	PN 100
Operation	
	Quick closing lever
Mount	
	Lateral
Connection to gauge body	
	Screwed nipple
Rotatable	
	No
Thru-way	
	Angled
Seat position	
	Inline
Valve stem thread	
	Internal
Drain	
	No
Ball-check valve	
	Yes

Model LGV-58
Offset valve with quick closing lever

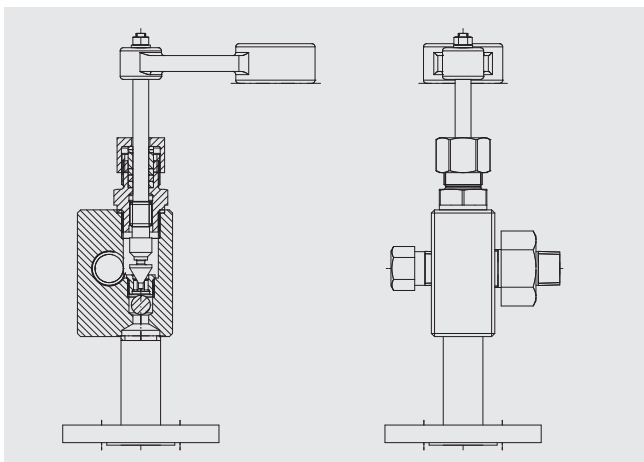

Specification	
Materials	
Valve body	Steel, stainless steel
Head piece	Stainless steel
Construction	
	Machined
Pressure range	
	PN 100
Operation	
	Quick closing lever
Mount	
	Top/bottom
Connection to gauge body	
	Screwed nipple
Rotatable	
	Yes
Thru-way	
	Offset
Seat position	
	Inline
Valve stem thread	
	Internal
Drain	
	Yes
Ball-check valve	
	Yes

Accessories

Illumination

The illumination is designed for backlighting of viewing slots in accordance with DIN 7081 and of viewing slots of mica indicators. Through the variation in the segment length and number, and also in the lighting strength, the illumination can be matched to the application. Versions for hazardous areas are also available.

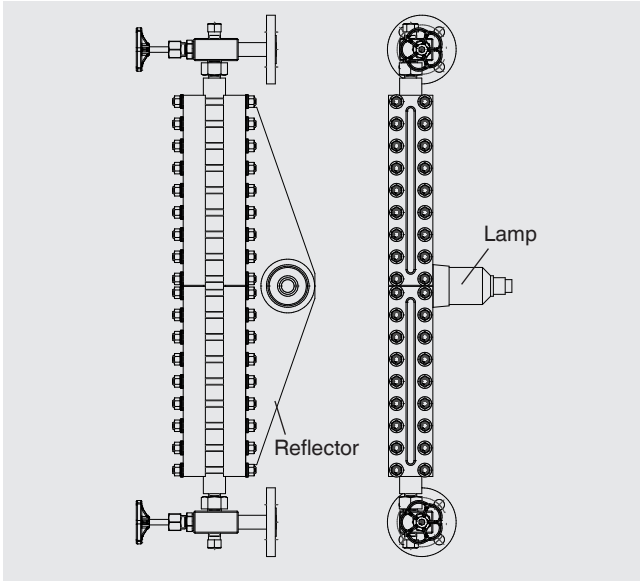

Acrylic glass extender

Using the acrylic glass extender, the sight glass can be insulated from low temperatures. The window is thus maintained through the insulation.

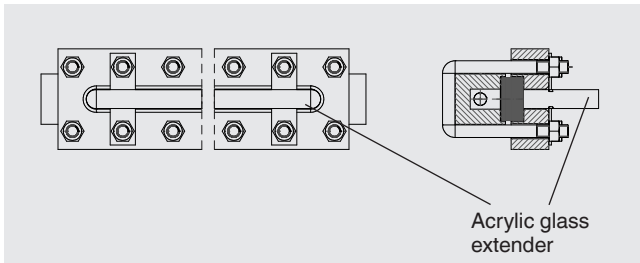

Mark for low-water level

This low-water mark serves as a warning indicator for the operator. Form, size and lettering vary depending on the design of the water-level indicator. The position of the low-water mark is always specified from the centre of the lower process connection.

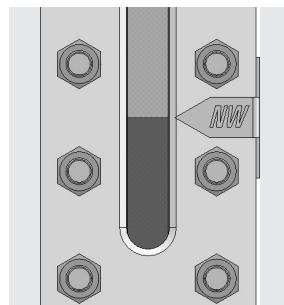

Spare parts

Name	Description	Order number
Glass set Rx	1x sight glass refl x borosilicate size x 1x flat gas et size x 1x cushion size x	
Glass set R2	Size 2 (140 x 34 x 17 mm)	119442
Glass set R3	Size 3 (165 x 34 x 17 mm)	119444
Glass set R4	Size 4 (190 x 34 x 17 mm)	119446
Glass set R5	Size 5 (220 x 34 x 17 mm)	119447
Glass set R6	Size 6 (250 x 34 x 17 mm)	119448
Glass set R7	Size 7 (280 x 34 x 17 mm)	119450
Glass set R8	Size 8 (320 x 34 x 17 mm)	119451
Glass set R9	Size 9 (340 x 34 x 17 mm)	119452
Glass set R10	Size 10 (370 x 34 x 17 mm)	119453
Glass set R11	Size 11 (400 x 34 x 17 mm)	119454
Glass set Tx	1x sight glass transparent borosilicate size x 1x flat gas et size x 1x cushion size x	
Glass set T2	Size 2 (140 x 34 x 17 mm)	119477
Glass set T3	Size 3 (165 x 34 x 17 mm)	119476
Glass set T4	Size 4 (190 x 34 x 17 mm)	119475
Glass set T5	Size 5 (220 x 34 x 17 mm)	119473
Glass set T6	Size 6 (250 x 34 x 17 mm)	119472
Glass set T7	Size 7 (280 x 34 x 17 mm)	119467
Glass set T8	Size 8 (320 x 34 x 17 mm)	119465
Glass set T9	Size 9 (340 x 34 x 17 mm)	119462
Glass set T10	Size 10 (370 x 34 x 17 mm)	119456
Glass set T11	Size 11 (400 x 34 x 17 mm)	119455
Glass protection		
Glass protection M2	1x mica shield size 2	501577
Glass protection M3	1x mica shield size 3	501578
Glass protection M4	1x mica shield size 4	501579
Glass protection M5	1x mica shield size 5	501580
Glass protection M6	1x mica shield size 6	501581
Glass protection M7	1x mica shield size 7	501582
Glass protection M8	1x mica shield size 8	501583
Glass protection M9	1x mica shield size 9	501585
Glass protection M10	1x mica shield size 10	501587
Glass protection M11	1x mica shield size 11	501588
Head piece		
Head piece KS1	1x head piece for LGG-E	503765
Head piece KS2	1x head piece for valve model LGV-01, LGV-51, LGV-52, LGV-53	503923
Head piece KS3	1x head piece for valve model LGV-03, LGV-56, LGV-57, LGV-58	503924
Head piece KS4	1x head piece for valve model LGV-18 (handwheel)	503619
Head piece KS5	1x head piece for valve model LGV-18 (lever, ball)	503620
Head piece KS6	1x head piece for valve model LGV-19 (handwheel)	503621
Head piece KS7	1x head piece for valve model LGV-19 (lever, ball)	503622

Ordering information

To order the described product the order number (if available) is sufficient.

Alternatively:

Model / Version / Process connection / Centre-to-centre distance / Valve type / Valve head arrangement / Process specifications (operating temperature and pressure) / Options

© 10/2010 KSR KUEBLER Niveau-Messtechnik GmbH, all rights reserved.
The specifications given in this document represent the state of engineering at the time of publishing.
We reserve the right to make modifications to the specifications and materials.



D-Ex Instruments, s.r.o.
Optátova 708/37
637 00 Brno/Czech Republic
Mob. +420 775 757 225
Tel. +420 541 423 225
ksr@dex.cz
www.dex.cz/ksr



D-Ex Instruments, s.r.o.
Pražská 3222/1
811 04 Bratislava/Slovakia
Mob. +420 775 757 225
Tel. +421 2 5729 7421
info@dex.sk
www.dex.sk/ksr



KSR KUEBLER Niveau-Messtechnik GmbH
Heinrich-Kuebler-Platz 1
69439 Zwingenberg/Germany
Tel. +49 6263 87-0
Fax +49 6263 8799
info@ksr-kuebler.com
www.ksr-kuebler.com