

# Illumination unit

## For sight glass level indicator

### Model LGI

KSR data sheet LM 33.02



for further approvals  
see page 2

#### Applications

- Better identification of liquid and gaseous phase
- Direct indication of the level
- Chemical industry, petrochemical industry, oil and natural gas extraction (on- and offshore), shipbuilding, machine building, power generating equipment, power plants

#### Special features

- Simple mounting of the illumination system
- Illumination types available for different applications
- Operating temperature: depending on illumination method
- Matching to the respective length of the glass indicator



Illumination unit with LED light source, model LGI-L

#### Description

An illumination unit model LGI can be used for transparent or refraction indicators. It improves the identification of the transition from the liquid to the gaseous phase.

There are various systems available, which can be matched to the respective application. Depending on the version, LEDs, a halogen bulb or sodium vapour lamp can be used as a light source.

## Model overview

Model	Description	Temperature range
LGI-L	Illumination unit with LED light source	-40 ... +85 °C
LGI-HD	Illumination unit with halogen bulb, Ex d	-20 ... +60 °C
LGI-LD	Illumination unit with LED light source, Ex d	-20 ... +60 °C
LGI-N	Illumination unit with sodium vapour lamp	-20 ... +150 °C
LGI-LE	Illumination unit with LED light source, Ex e	-25 ... +60 °C

## Approvals



### ■ Model LGI-L

Logo	Description	Country
	<b>EU declaration of conformity</b> RoHS directive	European Union

### ■ Model LGI-N

Logo	Description	Country
	<b>EU declaration of conformity</b> <ul style="list-style-type: none"> <li>■ Low voltage directive</li> <li>■ RoHS directive</li> </ul>	European Union

### ■ Models LGI-HD, LGI-LD

Logo	Description	Country
	<b>EU declaration of conformity</b> <ul style="list-style-type: none"> <li>■ Low voltage directive</li> <li>■ RoHS directive</li> </ul>	European Union
	<ul style="list-style-type: none"> <li>■ ATEX directive</li> </ul> Hazardous areas II 2GD Ex db IIC T6 ... T3 Gb II 2GD Ex tb IIIC T54°C ... T185°C Db IP66	
	<b>IECEx (option)</b> Hazardous areas Ex db IIC T6 ... T3 Gb Ex tb IIIC T54°C ... T185°C Db IP66	European Union

### ■ Model LGI-LE

Logo	Description	Country
	<b>EU declaration of conformity</b> <ul style="list-style-type: none"> <li>■ Low voltage directive</li> <li>■ RoHS directive</li> </ul>	European Union
	<ul style="list-style-type: none"> <li>■ ATEX directive</li> </ul> Hazardous areas II 2G Ex eb mb op is IIC T4 Gb II 2D Ex tb IIIC T130°C Db	

Approvals and certificates, see website

**Illumination unit with LED light source**  
**For sight glass level indicator (transparent indicator)**  
**Model LGI-L**

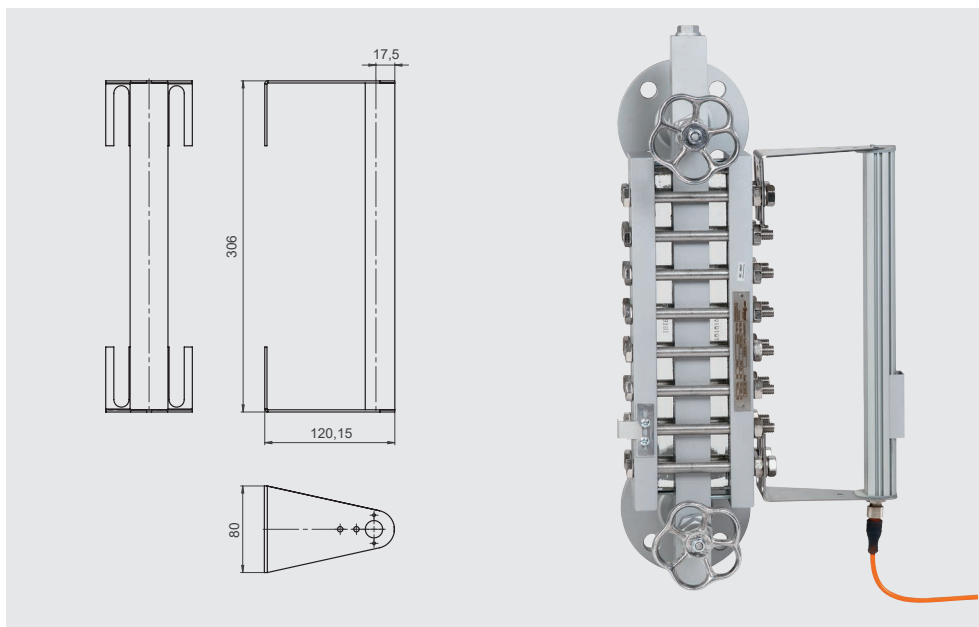

Specifications	
Light source used	LumiFlex Economy 35
Operating voltage	DC 24 V
Electrical power	4.8 W/m
Current	200 mA/m
Length	to 1,600 mm
Case material	Aluminium
Service life	40,000 h
Electrical connection	M12 connector (male)
Dimensions of illumination	
Length	Depending on visible length
Width	35 mm
Depth	120 mm
Ambient temperature	-40 ... +85 °C
Ingress protection	IP66
Weight	Length-dependent
Accessories (optional)	Connection cable

**Illumination unit with halogen bulb or LED light source  
For sight glass level indicator (transparent indicator)  
Models LGI-HD, LGI-LD**



II 2GD Ex db IIC T6 ... T3 Gb / II 2GD Ex tb IIIC T54°C ... T185°C Db IP66

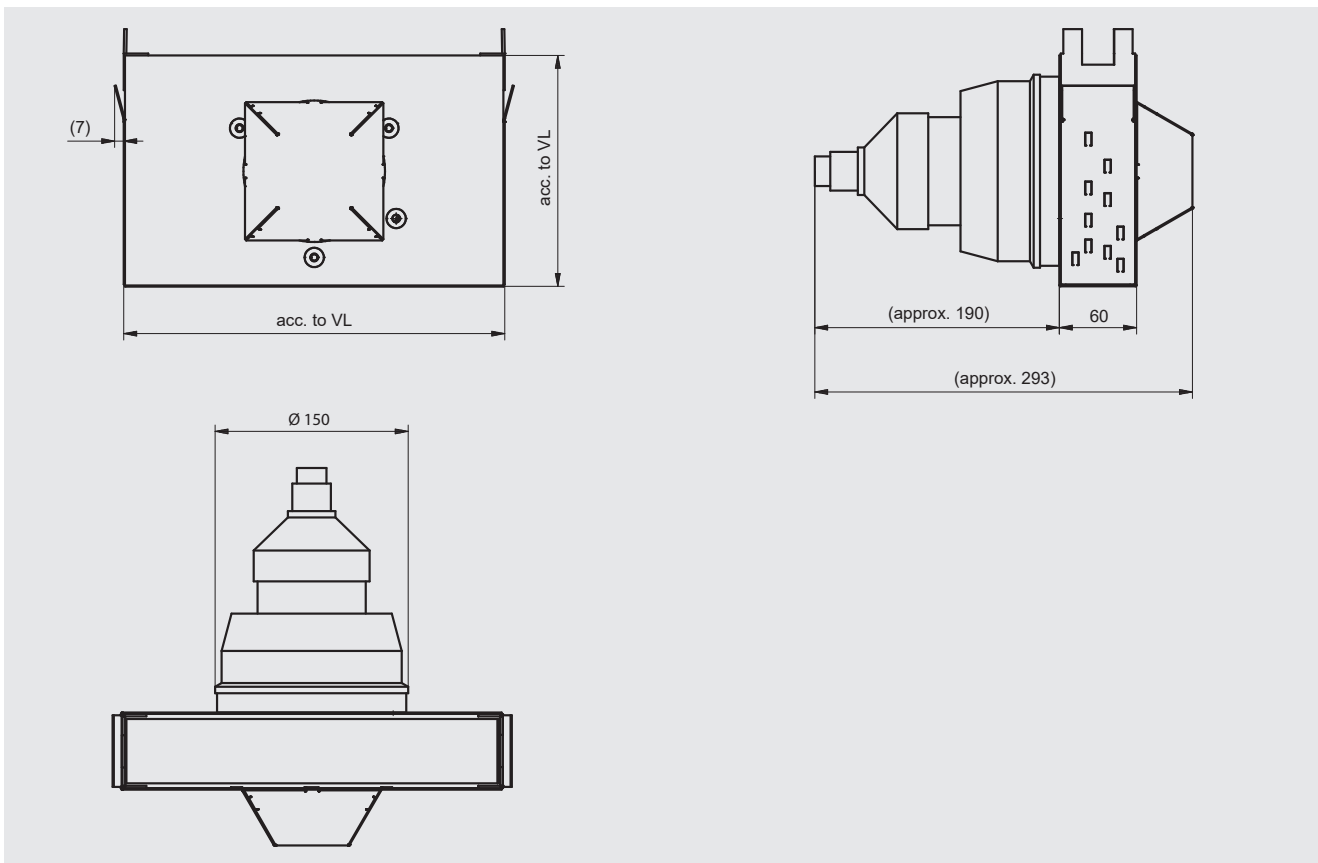

Specifications	Halogen bulb	LED light source
Light source used	OSRAM Halogen Classic A Eco 30 ... 77 W <sup>1)</sup>	Cortem LampLED 8 W
Operating voltage	AC 230 V	
Frequency	50 ... 60 Hz	
Electrical power	30 ... 77 W <sup>1)</sup>	8 W
Case material	Stainless steel 1.4301	
Service life	2,000 h	
Electrical connection	Cable entry 3/4 NPT female (adapter and cable gland optional)	
Dimensions of light control box		
Length	Depending on visible length	
Width	58 mm	
Depth	180 ... 300 mm <sup>1)</sup>	
Ambient temperature	-20 ... +60 °C	
Ingress protection	IP66	
Weight	Length-dependent	

1) Depending on the version

**Illumination unit with sodium vapour lamp  
For sight glass level indicators (refraction indicator)  
Model LGI-N**

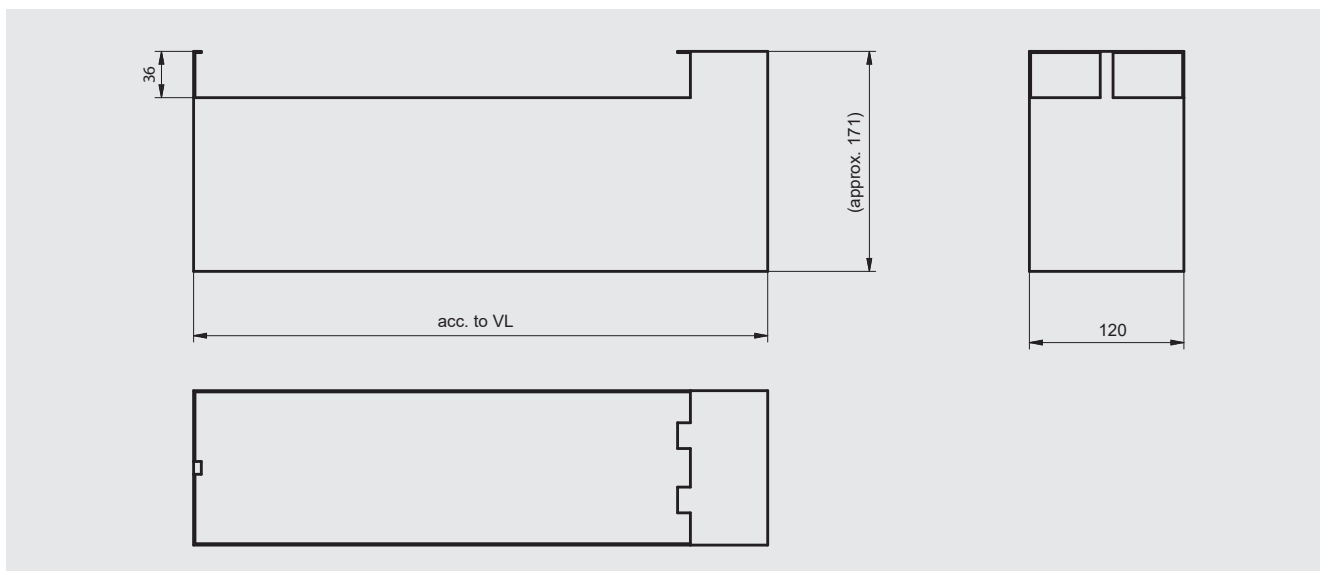

Specifications	
<b>Light source used</b>	Philips BY22d 18/9 TV-SOX-E 35 ... 55 W <sup>1)</sup>
<b>Operating voltage</b>	AC 230 V
<b>Electrical power of the lamp</b>	35 ... 55 W <sup>1)</sup>
<b>Current</b>	16 A
<b>Case material</b>	Stainless steel 1.4301 (304)
<b>Service life</b>	6,000 h
<b>Electrical connection</b>	Cable gland M20 x 1.5
<b>Dimensions of control cabinet</b>	
Height	380 mm
Width	380 mm
Depth	210 mm
<b>Dimensions of light</b>	
Length	Depending on visible length
Width	60 mm
Depth	60 mm
<b>Ambient temperature (light)</b>	-20 ... +150 °C
<b>Ingress protection</b>	IP65
<b>Weight</b>	
Light	approx. 3 kg
Control cabinet	approx. 15 kg

1) Depending on the version



**Illumination unit with LED light source**  
**For sight glass level indicators (transparent indicator)**  
**Model LGI-LE**

II 2G Ex eb mb op is IIC T4 Gb / II 2D Ex tb IIIC T130°C Db

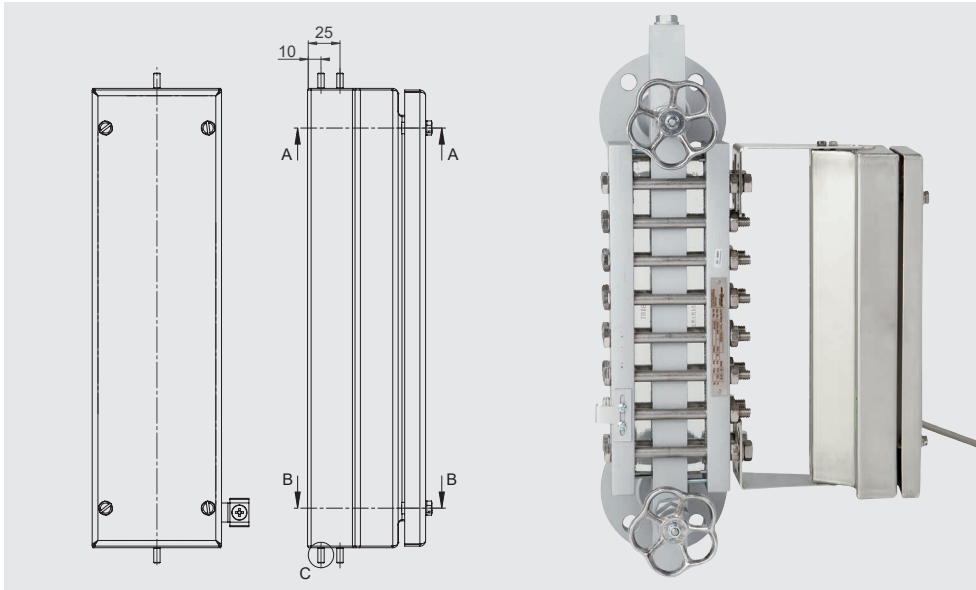

Specifications	LED light source
<b>Light source used</b>	TNCLS backlight
<b>Operating voltage</b>	<ul style="list-style-type: none"> <li>■ AC 220 ... 240 V</li> <li>■ AC 254 V</li> </ul>
<b>Frequency</b>	50 ... 60 Hz
<b>Electrical power</b>	approx. 4 W/m
<b>Case material</b>	Stainless steel 1.4404 (316L)
<b>Service life</b>	60,000 h
<b>Dimensions</b>	
Length	Depending on visible length
Width	100 mm
Depth	128 mm
<b>Ambient temperature</b>	-20 ... +70 °C
<b>Ingress protection</b>	IP66
<b>Weight</b>	7.3 kg/m

**Ordering information**

Model / Light source / Ambient temperature min./max. / Visible length / Sight glass level indicator present (serial number, order confirmation number) / Approvals / Options

© 02/2019 KSR KUEBLER Niveau-Messtechnik AG, all rights reserved.  
 The specifications given in this document represent the state of engineering at the time of publishing.  
 We reserve the right to make modifications to the specifications and materials.



**KSR KUEBLER Niveau-Messtechnik AG**  
 Heinrich-Kuebler-Platz 1  
 69439 Zwingenberg/Germany  
 Tel. +49 6263/87-0  
 Fax +49 6263/87-99  
 info@ksr-kuebler.com  
 www.ksr-kuebler.com